

Product Line-up	Type	HM	DXU	DXU-1002-L	Feeder Cabinet	MCU	MC	Custom Cabinet
	Grade	G1			G2		G3	

McDry

Product Line-up

HOME

G1 **HM** **1% internal humidity** **McDry**
MODEL (ultra-fast dehumidifying model) **high-performance model**

Mounting sites with a cabinet opening frequency of once every 10-20 minutes
Recommended IC package storage levels: 5a, 5, 4 and 3 (JEDEC standard)

With automatic energy-saving function When the cabinet is only opened infrequently, it switches to energysaving mode and uses only **60%** of normal operation mode power.

Low-energy design: Normal operation mode: Power consumption approx. **36%** lower (Compared with exiting product)
Low-energy operation mode: Power consumption approx. **60%** lower (Compared with exiting product)

HM-1001B	HM-1002B
 <p>The HM-1001B is a tall, silver cabinet with six glass doors arranged in a 3x2 grid. Each door has a silver handle. The cabinet is mounted on four casters. A 'McDry' logo is visible on the top-left door.</p>	 <p>The HM-1002B is a tall, silver cabinet with four glass doors arranged in a 2x2 grid. Each door has a silver handle. The cabinet is mounted on four casters. A 'McDry' logo is visible on the top-left door.</p>
<p>HM-1001B 1200ø (6-door)</p>	<p>HM-1002B 1200ø (4-door)</p>

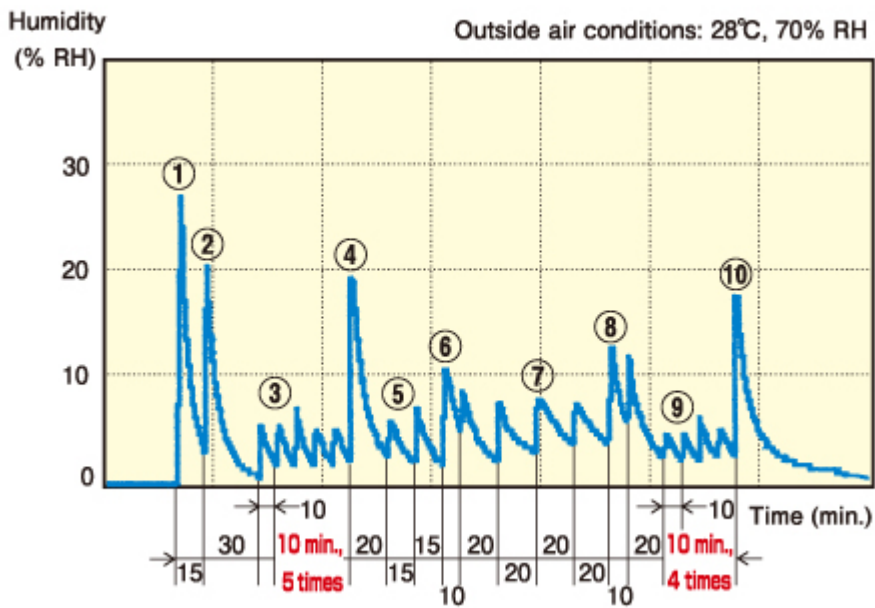
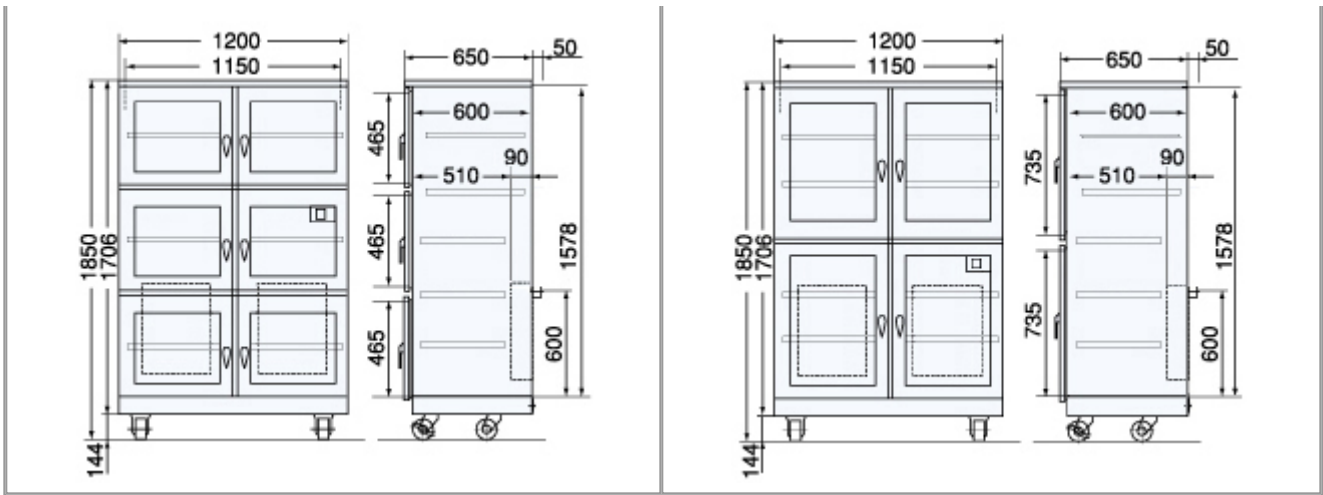

<Location and time of door opening/closing>

- (1) 2 doors C and D..... 2 min., both doors
- (2) 2 doors A and B..... 1 min., both doors
- (3) 1 of A, B, C, D, E and F..... 15 sec.
- (4) 2 doors A and B..... 1 min., both doors
- (5) 1 of E and F..... 15 sec.
- (6) 2 doors E and F 30 sec., both doors
- (7) 1 of E and F 20 sec.
- (8) 2 doors E and F..... 30 sec., both doors
- (9) 1 of A, B, E and F 15 sec.
- (10) 2 doors A and B..... 1 min., both doors

Features

- Ultra-powerful rapid dehumidification drying unit
- Digital humidity meter with large display panel
- 1 MΩ ground terminal
- Shelf load capacity: 100 kg

- No central pillar allows full shelf width to be used

Custom orders

N₂ gas socket can also be installed.

Model	HM-1001B	HM-1002B
Humidity regulator	Automatic dial regulator (RH)	
External dimensions	1200W×700D×1850H (mm)	
Internal dimensions	1150W×600D×1700H (mm)	
Capacity	Approx. 1200 Liters	
Drying unit	USF-7000×2	
Material	Steel with conductive coating (color: silver)	
Doors (magnetic)	6-door with glass panels	4-door with glass panels
Weight	200kg	190kg
Power supply	AC100V (50/60Hz)	
Power consumption	48 W/h (normal operation), 28 W/h (low-energy mode), max. 470 W	
Accessories	5 shelves, locks, humidity meter, casters (with stopper), ground terminal	

