

MC Model / 1%RH

Door Opening / Closing: Once every 0.5 - 2hrs.



MC-1001A
43 cf (6-door type)



MC-1002A
43 cf (4-door type)

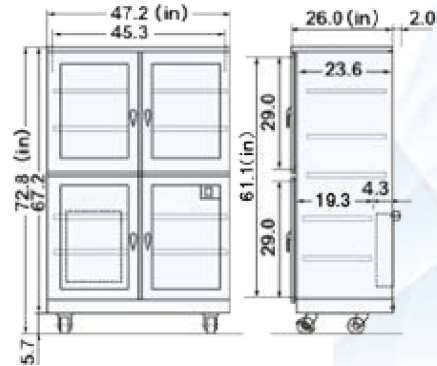
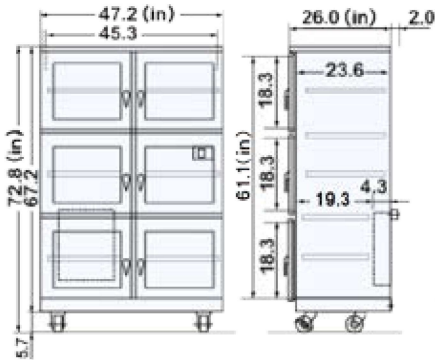

Specifications (Note: Specifications are subject to change due to product improvement.)

| Item | Model | MC-1001A | MC-1002A |
|------------------------|-------|--|--|
| External Dimensions | | 47.2W x 26.0 D x 72.8H (in) | 47.2W x 26.0 D x 72.8H (in) |
| Internal Dimensions | | 46.0W x 23.1D x 62.7H (in) | 46.0W x 23.1D x 62.7H (in) |
| Capacity | | Approx 43 Cu Feet (1200 Liters) | Approx 43 Cu Feet (1200 Liters) |
| Dry Unit | | US-5000F | US-5000F |
| Material | | High-grade steel construction with ESD-safe and Anti corrosion coating | High-grade steel construction with ESD-safe and Anti corrosion coating |
| Color | | Silver | Silver |
| Doors (Magnetic) | | 6 Doors with glass windows | 4 Doors with glass windows |
| Weight | | Approx 419 lbs. (190 kgs.) | Approx 396 lbs. (180 kgs.) |
| Electrical Requirement | | AC 120V (50/60Hz) 28W/h Max 350W | AC 120V (50/60Hz) 28W/h Max 350W |
| Accessories Included | | 5 shelves, Locks, RH meter, Caster, Ground terminal | 5 shelves, Locks, RH meter, Caster, Ground terminal |

Features:

1. Can maintain an RH level of 1%.
2. Equipped with a digital RH Meter.
3. Locking Doors.
4. Adjustable shelves.
5. Loading capacity 220 lbs. (100 kgs.)
6. Grounded to prevent static electricity.