

Isolated Digital I/O Unit  
16ch DI, 16ch DO  
**DIO-1616LN-ETH**



\* Specifications, color and design of the products are subject to change without notice.

**Features**

16 channels of Optocoupler isolated inputs (compatible with current sink and current source outputs) and 16 channels of Optocoupler isolated open-collector outputs (compatible with current sink type). This product has the 16 channels of Optocoupler isolated inputs (compatible with current sink and current source outputs) and 16 channels of Optocoupler isolated open-collector outputs (current sink type) whose response speed is 200μsec.

Common terminal provided per 8 channels, capable of supporting a different external power supply. Supporting driver voltages of 12 - 24 VDC for I/O. The digital input can be checked with the LED indicator.

**Optocoupler bus isolation**

As the Ethernet controller (PC) is isolated from the input and output interfaces by Optocouplers, this product has excellent noise performance.

With a digital filter to prevent wrong recognition of input signals from carrying noise or a chattering. \*1

This product has a digital filter to prevent wrong recognition of input signals from carrying noise or a chattering. All input terminals can be added a digital filter, and the setting can be performed by software.

Output circuits include Zener diodes for surge voltage protection and circuits for overcurrent protection.

Zener diodes are connected to the output circuits to protect against surge voltages. Similarly, Over-current protection circuits are fitted to each group of 8channels outputs.

The output rating is max. 60VDC, 100mA per channel

Operable in a wide range of 12 - 24VDC power

The product can be operated in the various environments with a wide range power supply of 12 - 24VDC. In addition, the FG terminal is equipped in the power connector.

Fail-safe function within \*1

The fail-safe function changes outputting to the specified pattern when communication errors such as LAN cable disconnection occur.

Compact design not restricting installation location (188.0(W) × 78.0(D) × 30.5(H))

Compact design of 188.0(W) × 78.0(D) × 30.5(H) does not require special installation location.

Digital I/O can be monitored remotely through Ethernet

Monitoring digital I/O is easy as it can be controlled remotely through Ethernet.

This product is an Ethernet-compliant digital I/O Unit used to provide a digital signal I/O function from PC LAN port.

Digital signals can be input and output at 12 - 24VDC.

16 channels of Optocoupler isolated inputs (compatible with both current sink and current source outputs) and 16 channels of Optocoupler isolated open-collector outputs (compatible with current sink type) are equipped. Also, including a digital filter function which prevents wrong recognition of input signals, output transistor protection circuit (surge voltage protection and over current protection), and the fail-safe function which changes outputting to the specified pattern when communication errors occur.

- \* The contents in this document are subject to change without notice.
- \* Visit the CONTEC website to check the latest details in the document.
- \* The information in the data sheets is as of February, 2021.

Diverse installations such as screw fastening, magnet (optional purchase), DIN rail are possible.

Installation on the floor / wall /ceiling is possible by screw fastening, with magnets (optional purchase), rubber feet, etc.

In addition, DIN rail mounting mechanism is equipped as standard with the product, making it easy to install the product within the panel or the device.

Easy-to-wire terminal connector adopted

Adoption of terminal connector (with screws) enables to achieve easy wiring.

Windows compatible driver libraries are attached.

Using the attached digital I/O driver API-DIO(WDM) makes it possible to create applications of Windows. In addition, a diagnostic program by which the operations of hardware can be checked is provided.

\*1: this is available in firmware version 1.10 or higher.

**Physical Dimensions**

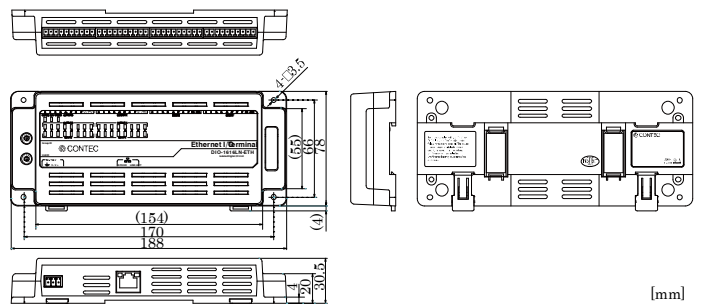

**Packing List**

- Product [DIO-1616LN-ETH] ...1
- I/O Connector...4
- Power Connector...1
- Rubber Fee ...4
- Disk \*1 [API-PAC(W32)] ...1
- First step guide ... 1
- Warranty Certificate ...1
- Serial Number Label ...1

\*1 The bundled disk contains the driver software and User's Guide.

## Specification

Item	Specifications	
<b>Input</b>		
Number of input signal channels	16 channels (8 channels share 1 common)	
Input format	Opto-isolated input (Compatible with current sink output and current source output) (Negative logic *1)	
Input resistance	15kΩ	
Input ON current	0.7mA or more	
Input OFF current	0.15mA or less	
Response time	Within 200μsec *2	
<b>Output</b>		
Number of output signal channels	16 channels (8 channels share 1 common)	
Output format	Opto-isolated open collector output (Compatible with current sink) (Negative logic *1)	
Output rating	Output voltage	60VDC (Max.)
	Output current	100mA (par channel) (Max.)
Residual voltage with output ON	0.5V or less (Output current ≤ 50mA), 1.0V or less (Output current ≤ 100mA)	
Surge protector	Zener diode CMZB68(TOSHIBA) or the equivalence for it	
Response time	Within 200μsec *2	
<b>LAN section</b>		
Transmission standard	10BASE-T/100BASE-TX	
Connector	RJ-45 connector	
LED	Speed(Yellow), Link / Act(Green)	
<b>Common section</b>		
Dielectric strength	1000VAC	
External circuit power supply *3	12 - 24VDC (±10%)	
Current consumption (Max.)	12VDC 250mA, 24VDC 150mA	
Operating conditions*4	-20 - 60°C, 10 - 90%RH (No condensation)	
Allowable distance of signal extension	Approx. 50m (depending on wiring environment)	
Physical dimensions (mm)	188.0(W) x 78.0(D) x 30.5(H) (No protrusions)	
Weight	300g (Not including the USB cable, attachment, connector)	
Connector	10 pin (screw-terminal) plug header x4	
Standard	VCCI Class A, FCC Class A, CE Marking (EMC Directive Class A, RoHS Directive)	

- \*1 Data "0" and "1" correspond to the High and Low levels, respectively.
- \*2 The Optocoupler's response time comes.
- \*3 External circuit power supply is required.
- \*4 To suppress the heating, ensure that there are spaces for ventilation (about 5cm) around this product.

## Support Software

Windows version of digital I/O driver API-DIO(WDM) [Stored on the bundled disk driver library API-PAC(W32)] The API-DIO(WDM) is the Windows version driver library software that provides products in the form of Win32 API functions (DLL). Various sample programs such as Visual Basic and Visual C++, etc and diagnostic program \*1useful for checking operation is provided.

For more details on the supported OS, applicable language and new information, please visit the CONTEC's Web site.

## List of Options

AC adapter (input: 90 - 264VAC, output: 12VDC 1.0A) :POA201-10-2  
Magnets for installation (For piece Set) :CPS-MAG01-4

\* Check the CONTEC's Web site for more information on these options.

## Name of each parts

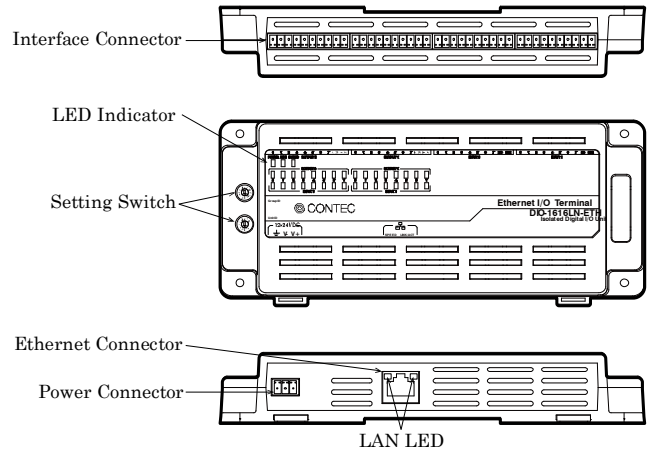

## Connecting an Interface Connector

When connecting the product to an external device, you can use the supplied connector plug. When wiring the product, strip off approximately 7 mm of the covering for the cable, and insert the bare wire by pressing the orange button on the connector plug. Releasing the orange button after the wire is inserted fixes the cable. Compatible wires are AWG 28 - 16.

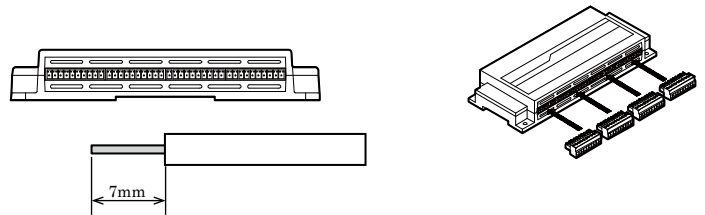

- Connector used:  
3.5mm pitch, 10 pin type of rated current 9.0A  
MC 1.5/10-G-3.5[PHOENIX CONTACT] (Equivalent)
- Compatible plug (Supplied)  
MC 1.5/10-ST-3.5[PHOENIX CONTACT] (Equivalent)  
Compatibule: AWG28-16

### Caution

- Removing the connector plug by grasping the cable can break the wire.
- Do not set or remove the interface connector when the power is on or during the communication.

### Signal Layout on the Interface Connector

The product can be connected to an external device using 10-pin connectors that is provided on the product face.

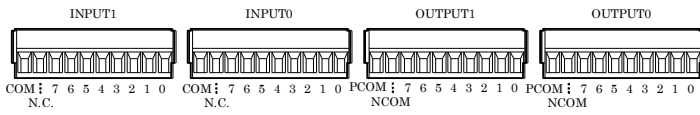

Connector	Pin No.	Signal	Meaning
INPUT0	0	IN00	+0 port (input)
	1	IN01	
	2	IN02	
	3	IN03	
	4	IN04	
	5	IN05	
	6	IN06	
	7	IN07	
	N.C.	N.C.	Not Connecte
COM	COM	Plus / minus	
INPUT1	0	IN10	+1 port (input)
	1	IN11	
	2	IN12	
	3	IN13	
	4	IN14	
	5	IN15	
	6	IN16	
	7	IN17	
	N.C.	N.C.	Not Connecte
COM	COM	Plus / minus	

Connect or name	Pin No.	Signal Name	Meaning
OUTPUT 0	0	OUT00	+2 port (output)
	1	OUT01	
	2	OUT02	
	3	OUT03	
	4	OUT04	
	5	OUT05	
	6	OUT06	
	7	OUT07	
NCOM	COM0(-)	Minus commo	
PCOM	COM0(+)	Plus commo	
OUTPUT 1	0	OUT10	+3 port (output)
	1	OUT11	
	2	OUT12	
	3	OUT13	
	4	OUT14	
	5	OUT15	
	6	OUT16	
	7	OUT17	
NCOM	COM1(-)	Minus commo	
PCOM	COM1(+)	Plus commo	

IN00 - 17	16 input signal pins. Connect output signals from the external device to these pins.
OUT00 - 17	16 output signal pins. Connect these pins to the input signal pins of the external device.
N.C.	This pin is left unconnected.
COM	Connect the positive or negative side of the external signal. These pins are common to 8 input signal pins.
COM0(-) - COM1(-)	Connect the negative side of the external signal. These pins are common to 8 output signal pins.
COM0(+) - COM1(+)	Connect the positive side of the external signal. These pins are common to 8 output signal pins.

### Connecting Input Signals

Input Circuit

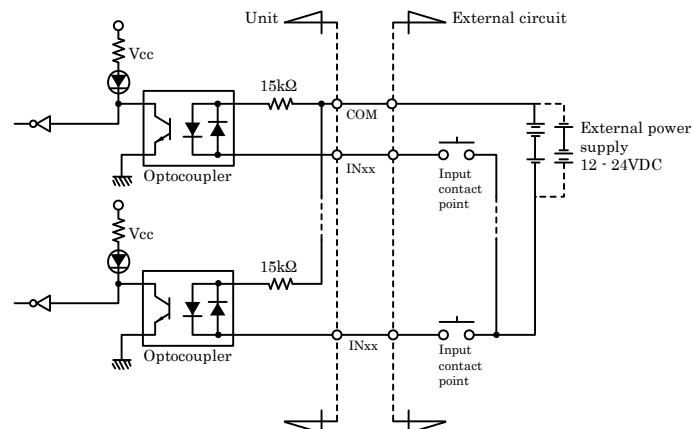
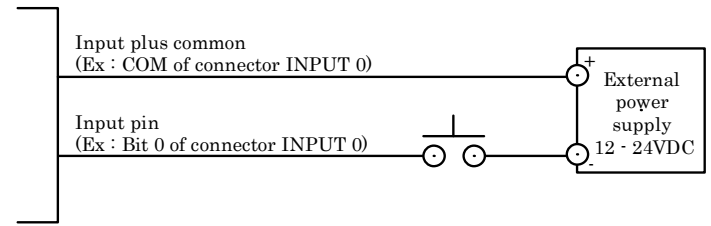

Figure above shows the input equivalent circuit for the interface section of this product. The signal input section consists of an Optocoupler isolated input

(compatible with both current sink output and current source output). An external power supply is therefore required to drive the input section of this product.

The power requirement for this product is about 0.8 mA per input channel at 12 VDC (about 1.6 mA at 24 VDC).

Connecting a Switch



An Example to use Bit0 of INPUT0

Examples of Connection to an External Device

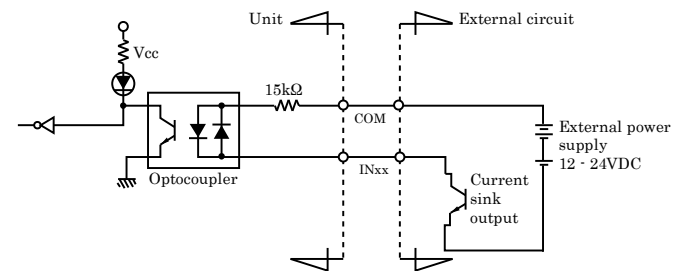

Example of a Connection between Input and Current Sink Output

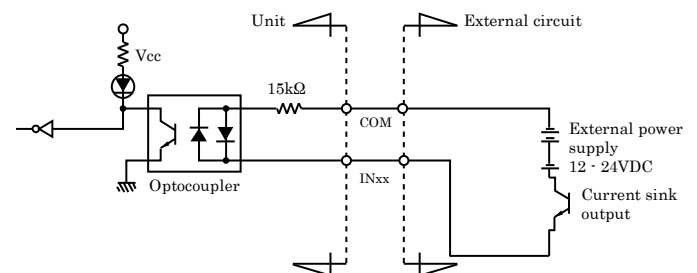

Example of a Connection between Input and Current Source Output

### Connecting Output Signals

Output Circuit

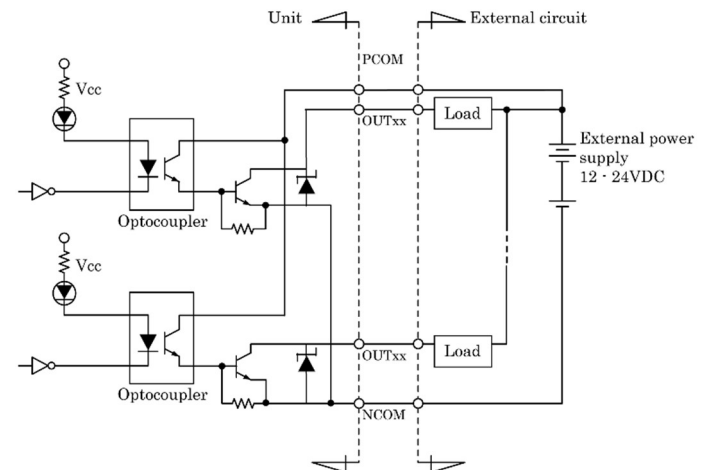

Figure above shows the output circuit for the interface section of this product.

The signal output section consists of an Optocoupler isolated open

collector output (current sink type). An external power supply is therefore required to drive the output section of this product.

The maximum output current rating per channel is 100 mA for the product.

As low saturation is used for outputting, connecting with TTL level input is also possible.

When outputting is on, residual voltages (low level voltage) between the collector and emitter are 0.5V or less at output current 50mA, and 1.0V or less at output current 100mA.

Zener diodes are connected to the output circuits to protect against surge voltages. Similarly, Over-current protection circuits are fitted to each group of 8channels outputs.

**Caution**

\* When the power is turned on, all output will be OFF.

**Connection to the LED**

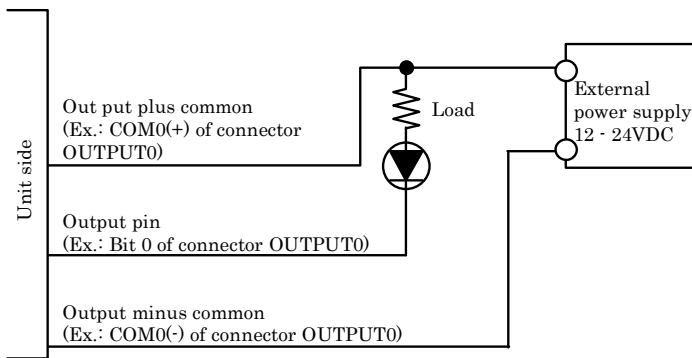

An Example to use Bit 0 of OUTPUT 0

**Example of Connection to TTL Level Input**

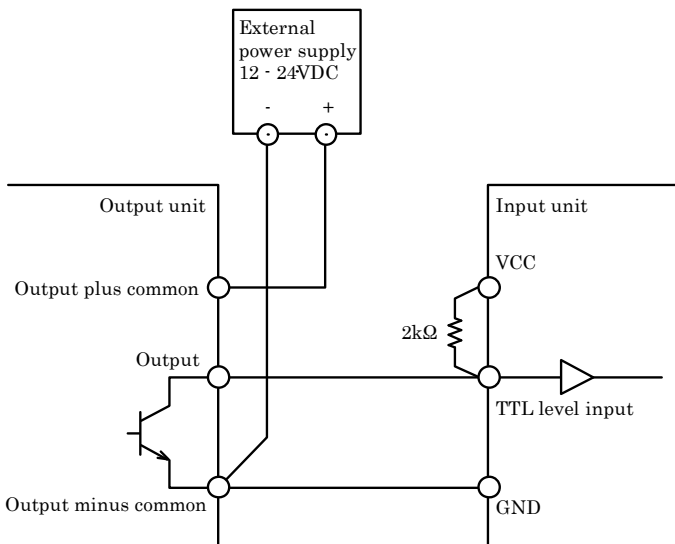

Connection Example of Output and TTL level Input Signal

**Example of a Connection between Input and Output Unit**

Figure below shows the example of a connection between input pin of input unit and output pin of output unit.

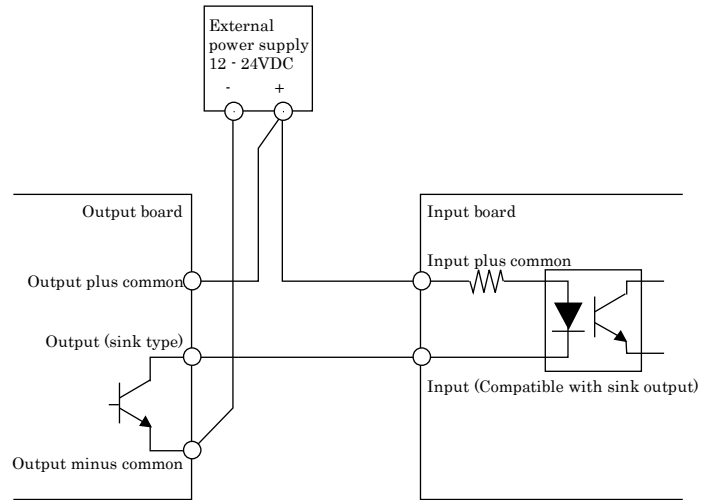

Example of a Connection between Output and Input