

N Series for USB  
Isolated 32-bit Up/Down Counter Unit  
CNT-3204IN-USB



\* Specifications, color and design of the products are subject to change without notice.

Features

32-bit up-and-down counter

The 32 bit up-and-down counter could have four channels and up to 500kHz maximum speed pulse input. Moreover, it can count 2-phase signals and mono-phase signals such as a rotary encoder and a linear scale.

Bus isolation

The USB (PC) is isolated from I/O interface by an isolators, this product has excellent noise performance.

Control input/output signals and input signals for controlling sampling functions

One control input signal and one control output signal are provided for each channel. This product can generate an interrupt, output an external signal, preset the counter, and clear it to zero when the count value matches the arbitrary value that is set. Moreover, this product has input signals (start/stop/clock) for controlling sampling functions.

Compact design not restricting installation location

Compact design of 188.0(W) × 78.0(D) × 30.5(H) does not require special installation location.

Compatible to USB1.1/USB2.0

Compatible to USB1.1/USB2.0 and capable to achieve high speed transfer at High Speed (480 Mbps)

Diverse installations such as screw fastening, with magnet(optional),and DIN rail mounting are possible

Installation on the floor / wall /ceiling is possible by screw fastening, with magnet, rubber feet, etc. In addition, DIN rail mounting mechanism is equipped as standard with the product, making it easy to install the product within the panel or the device.

Easy-to-wire terminal connector adopted

Adoption of terminal connector (with screws) enables to achieve easy wiring.

Windows compatible driver software

Using the counter input driver API-CNT(WDM) for USB makes it possible to create applications of Windows. In addition, a diagnostic program by which the operations of hardware can be checked is provided.

This product is a USB 2.0 supporting counter unit, which adds the function of counting pulse signals input from external devices through a USB port to a PC.

It has four channels of 32-bit up/down counters, allowing external devices such as a rotary encoder and a linear scale to be connected. The pulse signal inputting interface is optocoupler isolated.

Compact design, (188.0(W)×78.0(D)×30.5(H)mm), features flexibility in installation. The product can be set on the floor, wall, and inside the console or equipment with the DIN rail.

Input interface of pulse signal is opto-coupler isolated input.

\* The contents in this document are subject to change without notice.

\* Visit the CONTEC website to check the latest details.

\* The information in the data sheets is as of June 2020.

Specifications

Function Specifications <1/2>

Item	Specification
Input *1	
Counter	
Channel count	4 channels
Count system	Up/down counting (2-phase/Single-phase/Single-phase Input with Gate Control Attached)
Max count	FFFFFFFF (binary data, 32Bit)
Input type	Optocoupler isolated input
Input signal	Phase-A/UP 1 x 4 channels, Phase-B/DOWN 1 x 4 channels Phase-Z/CLR 1 x 4 channels
Input resistance	220 Ω (5V external power supply), 690 Ω (12V external power supply)
Response frequency	500kHz 50% duty
External Power	5VDC±10% or 12VDC±10%
Digital filter	0.1μsec - 1.6384msec or not used (can be independently set for each channel)
Counter start trigger	Software/External start input/Sampling start trigger
Counter stop trigger	Software/External stop input/Sampling stop trigger
Sampling	
Sampling start trigger	Software/External start input/Count match
Sampling stop trigger	Software/External stop input/Specification number/ Data transfer error/Count match
Sampling clock	Sampling timer/External clock input
Sampling timer	2μsec - 107sec 25nsec unit (can not be independently set for each channel)
External sampling start signal	Isolated TTL level input (Select Rise or Fall)
External sampling stop signal	Isolated TTL level input (Select Rise or Fall)
External sampling clock signal	Isolated TTL level input (Fall)
Response frequency	500kHz 50% duty
Control	
Control input signal type	Optocoupler isolated input
Control input channel	1 x 4 channels
Control input signal	- Preset (Select Rise or Fall) - Zero-clear (Select Rise or Fall) - Counter start/stop (Select Rise or Fall) - General-purpose input (positive logic) Software-selected from among the above four options
Response time	100μsec (Max)
Interrupt event	Count match (8 points), Counter error (2 points), Sampling factor (6 points), Carry/Borrow (1 points)

\*1 Use the shielded cable for this product to meet "CE EMC Directive".

Function Specifications <2/2>

Item	Specification
<b>Output *1</b>	
Control	
Control output signal type	Optocoupler isolated open collector output
Control output channel	1 x 4 channels
Control output signal	- Count match 0 output(one-shot pulse output) - Count match 1 output(one-shot pulse output) - Digital filter error output(one-shot pulse output) - Abnormal input error output(one-shot pulse output) - General-purpose output(Level output) Software-selected from among the above five options (Positive/negative logic is selected with the software)
One shot output signal amplitude	Selected between 10μsec, 100μsec, 1msec, 10msec and 100 msec (Can be set for each channel, within precision + 1μsec)
Response time	5μsec (Max)
Output rating	35VDC, 50mA(MAX)
External Power	5V - 12VDC±10%
<b>USB</b>	
Bus specification	USB Specification 2.0/1.1-compliant
USB transfer rate *2	12Mbps (Full-speed), 480Mbps (High-speed)
USB connector	USB mini B connector
Power supply	Self-power
<b>Power supply</b>	
Input voltage range	12 - 24VDC±10%
Current consumption (Max)	12VDC 200mA, 24VDC 90mA
Power supply connector	European type terminal 3.5mm pitch 3-pin jack connector
<b>Common section</b>	
Interface connector	Counter and Control : European type terminal 3.5mm pitch 8-pin jack connector x4 Sampling : European type terminal 3.5mm pitch 4-pin jack connector x1
Dielectric strength	1000VAC
Physical dimensions (mm)	188.0(W)×78.0(D)×30.5(H) (No projection included)
Weight	250g (Not including the USB cable, attachment, connector)
The length of cable (supplied)	USB cable(Type A - mini-B type) 1.8m

\*1 Use the shielded cable for this product to meet "CE EMC Directive".  
\*2 The USB transfer speed depends on the host PC environment used (OS and USB host controller).

Installation Environment Requirements

Item	Specification
Operating ambient temperature	-20 - +60°C *1
Operating ambient humidity	10 - 90%RH (No condensation)
Floating dust particles	Not to be excessive
Corrosive gases	None
Line-noise resistance *2	Line noise AC Line/±2kV Signal Line /±1kV(IEC61000-4-4 Level 3, EN61000-4-4 Level 3)
	Static electricity resistance Touch /±4kV(IEC61000-4-2 Level 2, EN61000-4-2 Level 2) Air /±8kV(IEC61000-4-2 Level 3, EN61000-4-2 Level 3)
Vibration resistance	Sweep resistance 10 - 57Hz /semi-amplitude vibration 0.15mm, 57 - 150Hz/2.0G 40minutes each in X, Y, and Z directions (JIS C60068-2-6-compliant, IEC60068-2-6-compliant)
Shock resistance	147m/s <sup>2</sup> (15G)/1ms/half-sine shock (JIS C 60068-2-27 -compliant, IEC 60068-2-27 -compliant)
Standard	VCCI Class A, FCC Class A, CE Marking (EMC Directive Class A, RoHS Directive)

\*1 When using the supplied AC adaptor POA 201-10-2, it is 0 - 40°C.  
\*2 When using the supplied AC adaptor POA 201-10-2.

AC adapter environmental condition (environmental specification)

Item	Specifications
Input voltage range	90 - 264VAC
Rated input current	300mA
Number of frequency	50 - 60Hz
Rated output voltage	12.0VDC
Rated output current	1.0A (Max)
Physical dimensions (mm)	47.5(W)×75(D)×27.3(H) (No protrusions)
Weight	175g
Operating temperature	0 - 40°C
Operating humidity	20 - 80%RH (No condensation)
Life expectancy *1	1.5 years (at the ambient temperature 40 °C when 100VAC is input and 1.0A is output) 4 years (at the ambient temperature 40 °C when 100VAC is input and 0.5A is output)
Allowable time of short interruption	20ms (Max) (When 100VAC is input and 0.55A is output) *2
Floating dust particles	Not to be excessive
Corrosive gases	None
Voltage compatible to the supplied AC cable	125VAC 7A

\*1 Life expectancy is four years when using this product.  
\*2 When short interruption occurs and

Physical Dimensions

Product

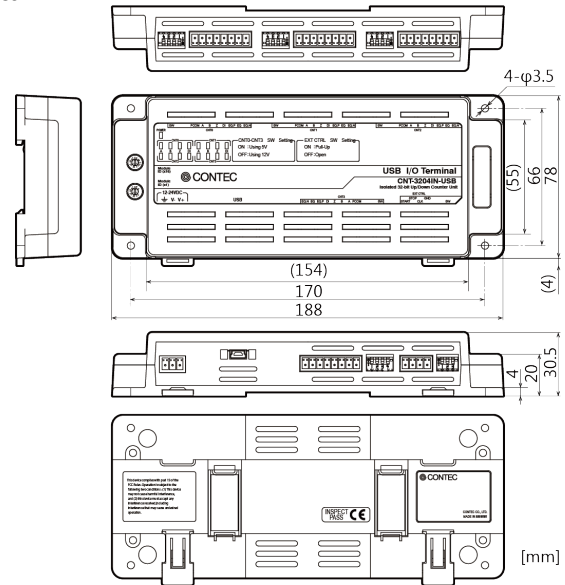

Physical dimensions of the supplied AC adapter (POA201-10-2)

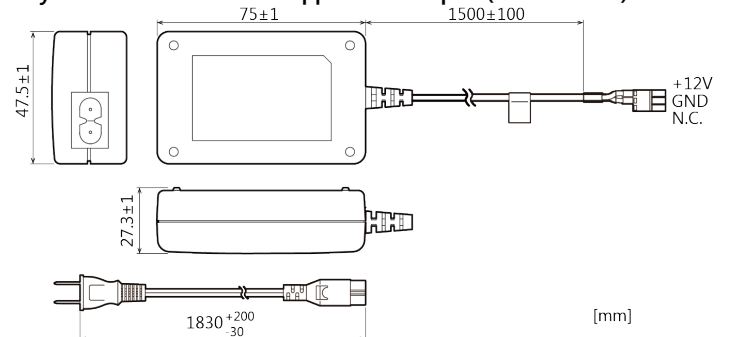

Packing List

- Product...1
- Setup Guide...1
- Warranty Certificate...1
- Serial Number Label...1
- USB Cable (1.8m)...1
- USB Cable Attachment on the main unit's side)...1
- Interface Connector(8-pin)...4
- Interface Connector(4-pin)...1
- Rubber feet...4
- AC Adapter...1
- AC Cable...1

## Support Software

You can use CONTEC support software according to your purpose and development environment. For more details on the supported OS, applicable languages, or to download the latest version of software, visit the CONTEC Web site.

Name	Contents	How to get
Driver software API-CNT(WDM) for USB	The API-CNT(WDM) is the Windows version driver software that provides products in the form of Win32 API functions (DLL). Various sample programs such as Visual Basic and Visual C++, etc and diagnostic program useful for checking operation is provided.	Download from the CONTEC website

## Optional Products

Product Name	Model type	Description
AC adapter	POA201-10-2 *1	Input: 90 - 264VAC, Output: 12VDC 1.0A
DIN rail fitting power supply	CPS-PWD-90AW24-01 *2	90W (Input: 100-240VDC, Output: 12VDC 3.8A)
	CPS-PWD-30AW24-01 *2	30W (Input: 100-240VDC, Output: 12VDC 1.3A)
	CPS-PWD-15AW12-01 *2	15W (Input: 100-240VDC, Output: 12VDC 1.3A)
Magnet	CPS-MAG01-4	Magnet (Four Piece Set)

\*1 The operating ambient temperature is 0 to 40 °C. It is the same adapter included in this package.

\*2 The operating ambient temperature is -20 to 70 °C.

Visit the CONTEC website for the latest optional products.

## Circuit Block Diagram

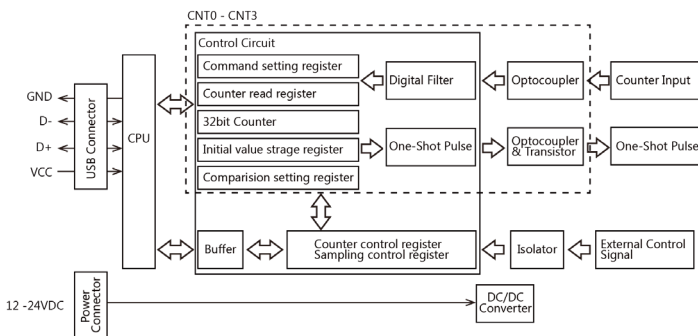

## Nomenclature of Product Components

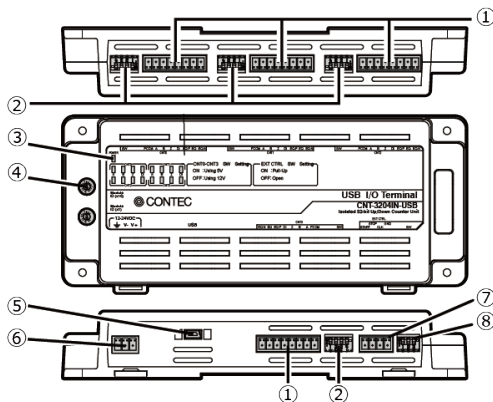

Number	Name	Number	Name
1	Interface connector (8-pin)	5	USB port (mini-B)
2	Input resistance setting switch	6	Power supply connector
3	LED indicator	7	Interface connector (4-pin)
4	Setting switch	8	Pull-up setting switch

## Interface Connector

CNT0 ~ CNT3	Signal name	Function
	PCOM	Plus common of input signal Connect the positive side of external power supply
	A	Phase-A input
	B	Phase-B input
	Z	Phase-Z input
	DI	Control input (this can be used as a general-purpose input/hardware event)
	EQ.P	Plus common of equal output Connect the positive side of external power supply
	EQ	Count equal output/General-purpose output
	EQ.N	Negative common of equal output Connect the negative side of external power supply

Support cable:

AWG28-16(Cable length should satisfy the power specification including the cable voltage drop)

EXT CTRL	Signal name	Function
	GND	Ground of external sampling start/stop/clock signal
	CLK	External sampling clock signal
	STOP	External sampling stop signal
	START	External sampling start signal
	START	External sampling start signal

Support cable:

AWG28-16(Cable length should satisfy the power specification including the cable voltage drop)

## Connecting Cable

**Counter Input/Control Input Signal/Control Output Signal Cable**  
Use the counter input/control input signal/control output signal cable listed below.

Applicable wire	AWG28 - 16
Cable Length	Opto-coupler isolated section: 50 meters approx. (vary depending on the wiring environment) Isolated TTL section: 1.50 meters approx. (vary depending on the wiring environment)

## Counter Input Circuit and Control Input Circuit

The figure below shows the equivalent circuit of counter input section and control input section of this product.

The signal input section consists of an opto-coupler isolated input (compatible with current sink output). Set an external power voltage and input resistance value according to the output specification of the external device to be connected.

As for the counter input section, connect both phase A and phase B for a two-phase input.

Connect either phase A or phase B for a single-phase input. If not using the Z phase, this does not need to be connected.

In addition, the control input section can also be used as the input section for the start / stop signal of general-purpose input and count operation, preset signal of count value.

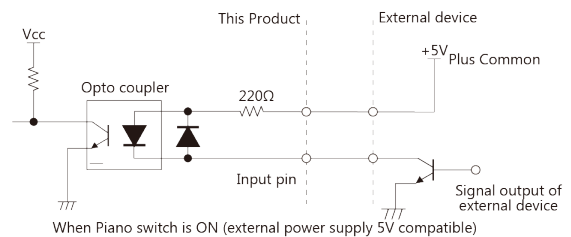

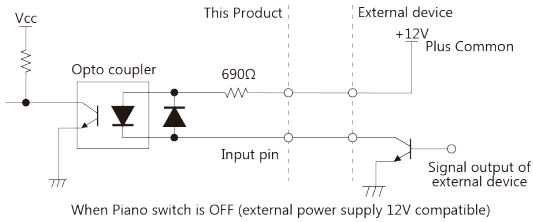

When Piano switch is OFF (external power supply 12V compatible)

**CAUTION**

To use external power (other than 5V or 12V); insert a current limiting resistor at the R position. The following expression is used to calculate current limiting resistance R with the external power supply as PV:

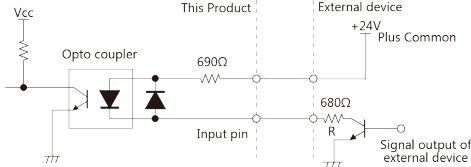

When Piano switch is OFF (external power supply other than 5V or 12V)

$$\frac{PV-12}{20} < Rk\Omega < \frac{PV-12}{15}$$

The expression is as follows;  
If PV=24V, use a 600Ω < R < 800Ω resistor.

### Control Output Circuit

The figure below shows the output circuit of control output section of this product. The signal output section consists of an opto-coupler isolated open collector output (current sink type). An external power supply is therefore required to drive the output section of this product. The maximum output current rating per channel is 50 mA for the product.

Zener diodes are connected to the output transistor to protect against surge voltages. As for the control output section, it is also possible to output a one-shot pulse signal at the time of hardware event occurs, such as a general-purpose output and count match.

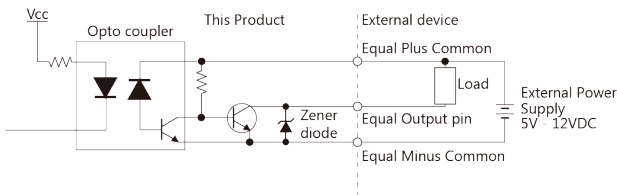

**CAUTION**

- Negative logic is set as default. (Negative logic is also set when setting is empty)
- When the power is turned on, all output will be OFF.

### Sampling Control Input Circuit

The figure below shows the circuit of signal input for sampling control section of this product. These inputs are used for the start signal, the stop signal and the clock signal of sampling operation. The signal input section consists of a digital isolated and TTL input. This section can set the pull-ups, so that the device that outputs a TTL level signal and also the device that outputs an open-collector can be connected. The pull-up voltage is 5V. If it is necessary to pull-up with different voltage such as 3.3V, turn off the pull-up setting and pull-up at the external device side.

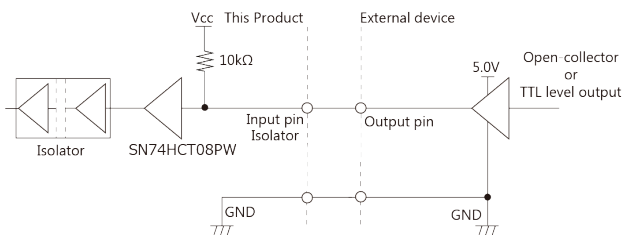

When Piano switch is ON (pull-up with 5V, 10kΩ)

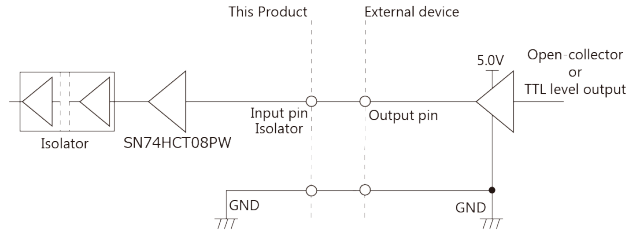

When Piano switch is ON (No pull-up)

**CAUTION**

Turn on the pull-up setting when sampling control input is not used. It may affect the unconnected control input terminal when pull-up voltage is not connected.

### Setting Switches

There are two setting switches. "x16" and "x1" represent high bits and low bits of Module ID respectively.

Factory settings "00" can be used when only one device per model is connected to one computer. Each device should be assigned a unique Module ID in the range of 00 - 7Fh when several devices with the same model are being connected.

Module ID	Setting description
Module ID (x16) [0]	00 - 7Fh It is a setting range for module IDs.
Module ID (x1) [0]	FFh Use only when upgrading the firmware.
Module ID 00h (Factory settings)	

**CAUTION**

When setting with Module ID(x1) = F, Module ID(x16) = F, Module ID is only used for upgrading the firmware. This setting cannot be used to distinguish or keep tracks of the devices.

### LED Indicator

LED name	LED color	Status	Description
POWER	Green	OFF: Power-OFF ON: Power-ON	Display power status
A, B, DI	Yellow	OFF: Input-OFF ON: Input-ON	Input status
Z	Yellow	Positive logic: OFF: Input-ON ON: Input-OFF Negative logic: OFF: Input-OFF ON: Input-ON	Input status

### Input Resistance Setting Switch

Switch number	Input signal	Setting description
CNT0 ~ CNT3 SW	General-purpose input	ON: 5V, 220Ω OFF: 12V, 690Ω
		ON: 5V, 220Ω OFF: 12V, 690Ω
Factory settings: All set to OFF	Phase-Z input	ON: 5V, 220Ω OFF: 12V, 690Ω
		ON: 5V, 220Ω OFF: 12V, 690Ω
Factory settings: All set to OFF	Phase-B input	ON: 5V, 220Ω OFF: 12V, 690Ω
		ON: 5V, 220Ω OFF: 12V, 690Ω
Factory settings: All set to OFF	Phase-A input	ON: 5V, 220Ω OFF: 12V, 690Ω
		ON: 5V, 220Ω OFF: 12V, 690Ω

### Pull-Up Setting Switch



5V pull-up of input signals for sampling control can be enabled or disabled with the piano switch equipped on the bottom face of the product. Set the switch to OFF when the other voltage such as 3.3V is used, and pull-up externally. And set the switch to ON when the input signals for sampling control are not used.

Switch number	Input signal	Setting description
Factory settings: All set to ON	External sampling start signal	ON: Pull-up with 5V, 10kΩ OFF: No pull-ups
		ON: Pull-up with 5V, 10kΩ OFF: No pull-ups
Factory settings: All set to ON	External sampling stop signal	ON: Pull-up with 5V, 10kΩ OFF: No pull-ups
		ON: Pull-up with 5V, 10kΩ OFF: No pull-ups
Factory settings: All set to ON	External sampling clock signal	ON: Pull-up with 5V, 10kΩ OFF: No pull-ups
		ON: Pull-up with 5V, 10kΩ OFF: No pull-ups

## Power Supply Connector

This product must be connected by using the 12-24VDC power supply (in a self-powered state).

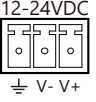
Connect the external power supply to the power supply connector.

 <p>12-24VDC</p> <p>Attached connector: European type terminal 3.5mm pitch 3-pin jack connector</p>	Mark	Description
		Frame ground
	Vi-	Power supply (GND)
	Vi+	Power supply (12 - 24VDC±10%)

The power supply connector is 12 - 24VDC±10% input, and the connector set in the product is MC 1,5/ 3-G-3,5 [PHOENIX CONTACT] (or equivalent). When supplying the power with the compatible connector plug [MC 1,5/3-ST-3,5[PHOENIX CONTACT] (or equivalent), strip off the end of the cable and insert it to the connector plug, then secure the cable by tightening the screws.

Likewise, when connecting the FG pin to the ground (earth), strip off the end of the cable and insert it to the connector plug, then secure the cable by tightening the screws.

**⚠ CAUTION**

If you use this product in a noisy environment, connect the FG pin of the product to the ground (earth) to stabilize the operation.

**About a power rise**

Input voltage range: 12 - 24VDC plus or minus 10 percentages. Use the power that can rise in the input voltage range of 11.4VDC or greater within 10ms. Other power supply may cause a damage to the product or an accident.

