

**5 million pixels (2448x2048) with 5 million points spectral data.
High luminance 17 billion cd/m² with built-in ND filter.**

2D Spectroradiometer *SR-5100*

2D spectroradiometer contributes to maintaining high quality of various products as it can evaluate the spectral characteristics of light sources or objects with 5 million pixels.

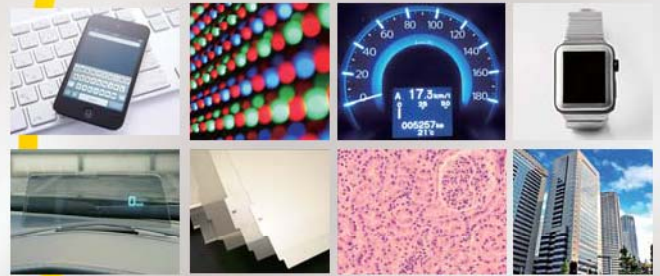

Here is the ultimate solution that spectroscopic and colorimetry via 2D spectroradiometer.



By Non-Destruction and Non-Contact, 2D spectroradiometer instrument that contributes to maintaining high quality of various products as it can evaluate the spectral characteristics of light sources or objects with 5 million pixels.



Replacing the measured numerical data with pseudo-color, grayscale, and RGB images, it enable to display Mura of the object.



By measuring spectrum and analyzing the spectrum of the object, it can evaluate sample for not only characteristics that are difficult to detect with the human eye or filter-typed imaging luminancemeter, but also refracted light of objects and lighting simulations.

- High resolution 5 million pixels (2448×2048) spectral measurement and high luminance (17 billion cd/m²) .
- Non-destructive and non-contact, 5 million points of spectral evaluation for the characteristics of light sources, spectral transmittance characteristics of materials, and spectral reflectance characteristics with high accurate 1nm pitch measurement.
- Microscope system enables to evaluate spectral data for small area with um pixel level. (micro spectroscopy)
- Imaging spectroradiometer with the same performance as a spot type spectroradiometer.
- High luminance and chromaticity accuracy is guaranteed by calibration using a light source with traceability.
- High-precision and high-speed convertible model that takes advantage of 2way measurement methods of spectral and XYZ filters.
- Application software and SDK included as standard.
- Measurement function : Luminance, Chromaticity(x,y, u',v'), Correlated color temperature, Dominant wavelength, Excitation purity, Peak wavelength, Irradiance, Spectral radiance, L*a*b*, Hue-Chroma, RGB

Spectral mode

1 High accuracy measurement by spectrophotometry method of each 1 nm.

Measurement wavelength select from 1nm, 5nm and 10nm pitch.

3 Measurement of lower luminance from 0.5 cd/m².

Measure 0.5 cd/m² to 17 billion cd/m² and luminance, chromaticity and spectrum accurately.

2 Measure absolute value.

It can measure high accurate luminance and chromaticity by world first complete traceability and calibration.

4 Measurement of designated range.

Measurement time will be faster when setting designated measurement area or wavelength range.

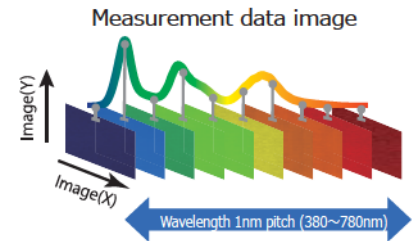

XYZ(Filter) mode

1 High accuracy measurement up to 0.005 cd/m² that is in ultra-low luminance range.

Measure luminance and chromaticity from 0.005 to 100,000 cd/m²* with high accuracy by using our own optical XYZ filter.
*Standard illuminant A.

2 High speed measurement.

Measurement for luminance and chromaticity is possible in approx.12 sec when luminance of light source is 200 cd/m².

3 High accurate chromaticity.

The newly developed high accurate XYZ optical filter that chromaticity accuracy is within ±0.008, and achieved high correlation the sensitivity of human eyes.
*Standard illuminant A and standard colored glass filter.

Common function

1 5 Mega pixel CMOS sensor.

Measurement of 2448 × 2048 pixels.

2 Arbitrary shape of measuring area setting.

Measurement area setting such as polygon, rectangle, circle is available freely. It can flexibly correspond to various instrument panels, design displays, etc.

3 Synchronous measurement.

Measure stably by inputting the synchronization signal when measuring the blinking light source such as OLED.

4 Frequency measurement.

Measure stably by setting frequency when measuring the pulse emitting light source. *4 to 20,000 Hz

5 Multipoint extraction & measurement.

Specifying multipoint of emitting area, and extracting emitting points from each specified area based on threshold value, and measuring them automatically.

6 Layer function.

It is most suitable for light-shade measurement of the object that have wide dynamic range.

7 Diagonal correction function.

Correcting tilting image of the measuring surface. Once a tilting correction setting is specified in a recipe, measured images in subsequent measuring are corrected automatically.

8 Object color mode/ L*a*b*, Hue-Chroma.

Display the object color value by calculating standard white board and actual measurement data.

9 External control efficiency.

In addition to our standard SDK, Saving as the HDF5 format read by MATLAB®.

Support standard application software to measure and evaluate efficiently with easy operation. (Japanese/English)

You can control the SR-5100 series and retrieve measured data, save data, convert measured data into image via Computer.

The application software conducts various types of data processing and data analyzing efficiently.

Two types mode are available for your usage.

•Measurement mode

Full functions are available including SR-5100 series control.

•Review mode

Viewer software for viewing image data and analyzing measured data, and can analyze measured data at other place without the instruments.

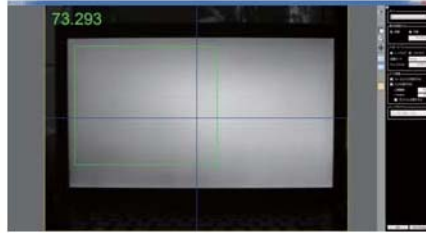

•Live view

Real time image that is automatically adjusted by brightness show on PC. You can check measurement area of target and adjust the position via Live-view image.

•Focusing assist

This function is used to adjust focus at real time. The ratio of focusing is displayed, and you can adjust stable focusing.

•Optimizing area

Measuring condition is optimized at specified area by specifying area even if there are some light in out of measurement area.

•Scale display

Pixel number of specified area and length equivalent to pixel number(mm) is shown.

•Zoom/Move

You can zoom and move the position anywhere in the live image.

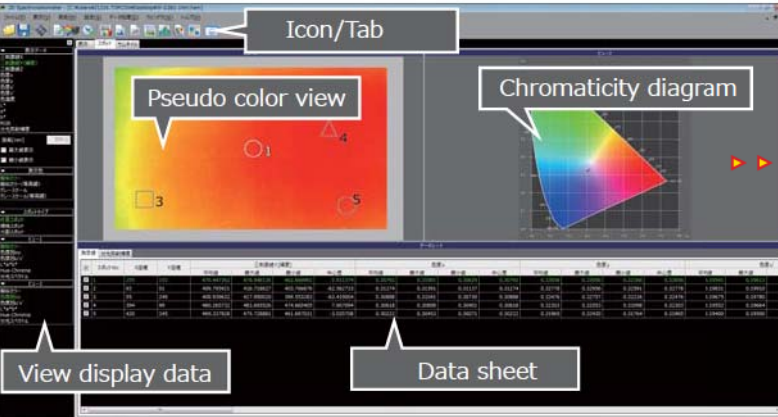

Measured data can paste to spreadsheet software.

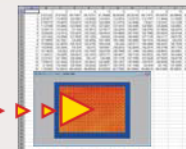

Measured data in each view can save as CSV, txt, or image file (BMP/JPG/PNG), and can paste to spreadsheet software such as Excel.

Selectable data item in view window.

1. Tristimulus values (X, Y, Z)
2. Chromaticity x, y
3. Chromaticity u', v'
4. Colorimetric system $L^*a^*b^*$
5. R,G,B
6. Spectral radiance

Main view window

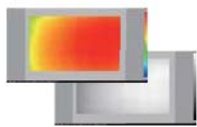

1. Pseudo color / Gray scale
Software-colored image and 16,384 steps gray scale present the difference in luminance / chromaticity on measuring area. This view is suitable for uniformity measuring.



8. Histogram View
The statistical graphics indicates the number of pixel in the vertical axis and the tristimulus value or chromaticity in the horizontal axis.



15. Spectral radiance image
Measured data is displayed as an image for each wavelength.

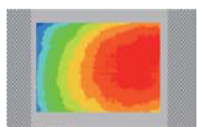

2. Contour view
This view use contour lines to indicate the profile of each tristimulus value.



9. Measured images comparison
Differences of measured each images and differences by ratio calculation are displayed as images. By entering mathematical expressions, you can freely define the comparison method.

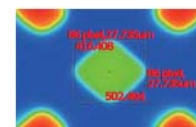

16. Ruler & Ruler correction
The numerical value (pixel number or th "mm" size equivalent to the pixel number), which are displayed by dragging the mouse left button. Ruler correction can set the difference with real size.



3. Split spot view
The Image divided with grid pattern shows in this view, and average value in the each divided area is calculated.



10. Spot comparison
Differences of measured each images and differences by ratio calculation are displayed as images.



17. Auto spot
Create the grid pattern spots automatically by parameters. Measured data is displayed as an image for each wavelength.

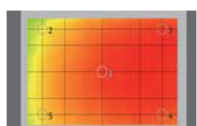

4. Standard spot view
Four type of Measuring standard available such as JEITA standard (EIAJ ED-2522/ ED-2710). You can customize the measuring spot size and the number of measuring spot.

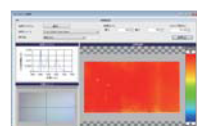

11. Spectral search
The matching ratio of each spectral is displayed.



18. Auto Time-series graph view
The horizontal axis represents time passage and vertical axis represents the time-series analysis results as a graph. Data sheet display the measured value of each spot in the chronological order on the spread sheet.

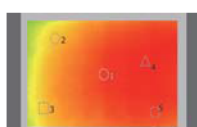

5. Random spot view
Max 999 measuring spots can place on an image. Shape of measuring spots can select from Circle, Rectangle, Polygon (max 127 vertex).



12. Spectrum
Spectral radiance for each wavelength of the measurement spot is displayed. The horizontal axis represents wavelength and the vertical axis represents spectral radiance.

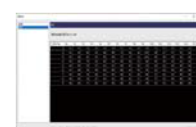

19. Color rendering index
Color rendering index displays for each spot in the measured image of the property of the light source (how the color looks compared to the standard illuminant).
• General color index (Ra)
• Special color index (R9-R15)

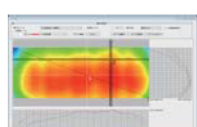

6. Cross section view
Tristimulus value on the cross-section line is expressed as graph. The cross-section line are selectable from cross line or diagonal line (max.10 lines). Line width expand.



13. Pixel data
Spectrum on any pixels in measured image and various measured value are displayed. Peak of wavelength is displayed.



7. x, y, u', v' Chromaticity diagram view
Chromaticity value on the spot can plot on the x, y or u', v' diagram. The plotted diagram can scale up.

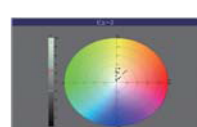

14. $L^*a^*b^*$
Chromaticity $L^*a^*b^*$ of each spot is plotted on the chromaticity diagram, and the color distribution can confirm. Also, chromaticity diagram is possible to zoom up for checking where plotted points concentrated.

Principal use



- Luminance / chromaticity and spectral evaluation of LCDs, OLEDs, QDs, lasers, micro LEDs and related components and materials
- Emission distribution characteristics and spectral evaluation of automobile meter panels and interior / exterior lighting
- Evaluation of luminance / chromaticity mura and spectral of the light emitting part of LED lighting and OLED lighting
- Spectral evaluation of all objects in the landscape indoors and outdoors
- Spectral evaluation of textile dyed fabrics
- Skin care assessment of skin blemishes and pigmentation
- Analysis of absorption, reflection and transmission characteristics
- Measurement of film and glass coating mura and interference fringes
- Analysis and quantification evaluation of slight differences in the staining status of pathological tissue (SR-5100HM + microscope)

Usage examples

- ❖ Evaluation of luminance, chromaticity and spectrum unevenness for OLED, LCD, μ /mini LED and related materials.

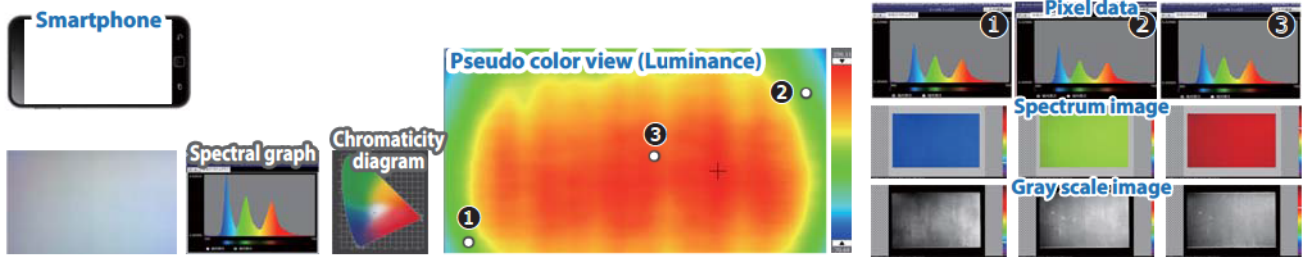

"Color shift" occurs due to low durability of OLED' s RGB organic matter, and it is detected by shift of spectrum, luminance and chromaticity.

- ❖ Evaluation for automotive interior and exterior lamp.



Evaluation for luminance unevenness, spectrum of specified points, luminance or chromaticity of object such as indicator.

Sunlight simulation

- ❖ Skin care assessment

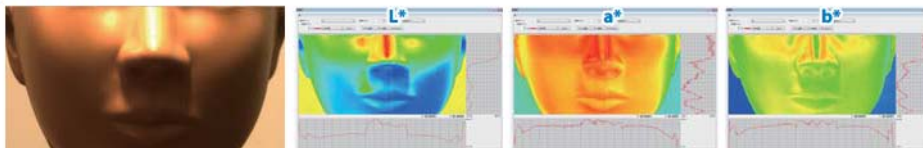

- ❖ Evaluation for automotive interior



- ❖ Multi points color rendering index

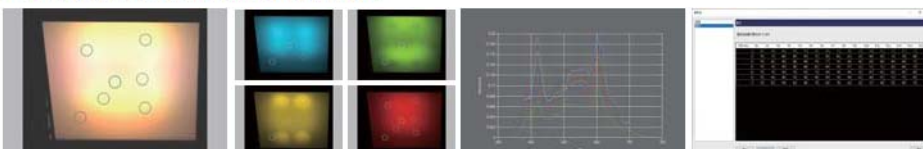

- ❖ Mini-LED evaluation

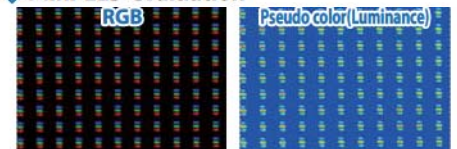

- ❖ Color chart evaluation

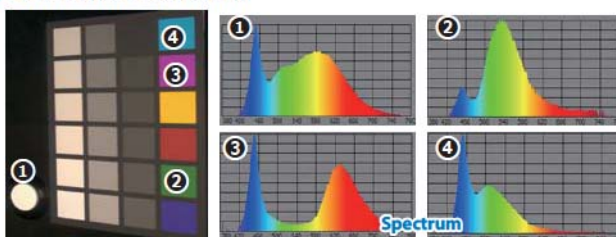

- ❖ Enviromental measurement



- ❖ Spectral search

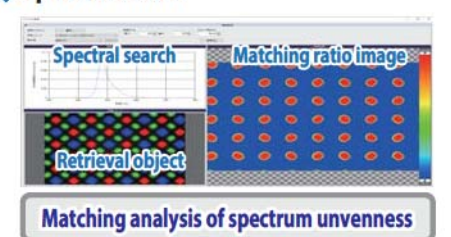

Matching analysis of spectrum unevenness

❖ SR-5100HM C-mount adapter application example



C-mount
(option)

Enable to evaluate high accurate spectrum distribution with contactless by microscope lens, zoom lens and system integration.

ZOOM lens



Large area measurement

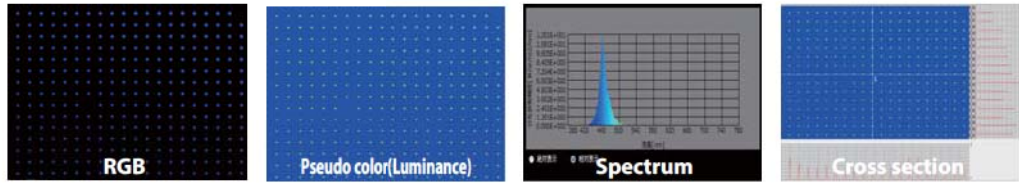

Expanding of FOV for Higher Throughput w/accurate Luminance, Chromaticity and Wavelength Peak.

SR-5100HM+Zoom lens

	1x Zoom	0.5x Zoom	0.3x Zoom
Measurement area [mm]	6.8x5.7	13.5x11.3	22.53x18.83
Resolution [$\mu\text{m}/\text{pixel}$]	3.45	6.9	11.51

Microscope



Micro-spectral measurement

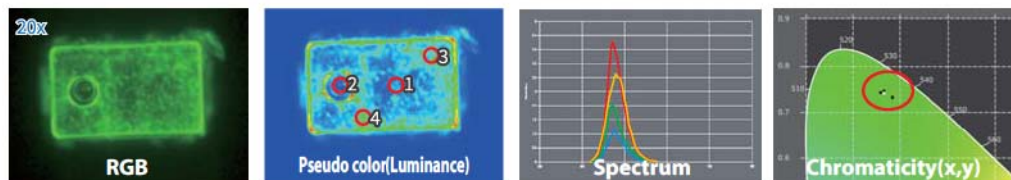

Evaluate of very small lighting area about Micro or Mini LED by combining with microscope.

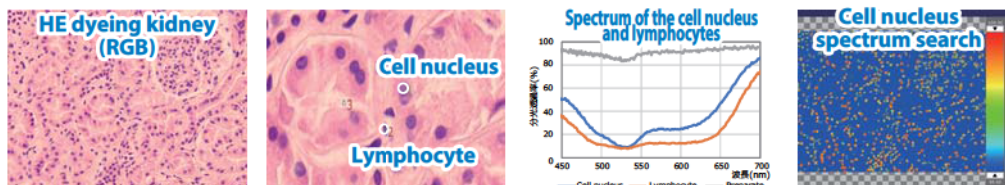

SR-5100HM+Microscope(Objective lens)

	5x	10x	20x
Measurement area [mm]	1.35x1.13	0.68x0.57	0.338x0.283
Resolution [$\mu\text{m}/\text{pixel}$]	0.69	0.35	0.17

High magnification for observation

	50x	100x
Measurement area [mm]	0.135x0.113	0.068x0.057
Resolution [$\mu\text{m}/\text{pixel}$]	0.069	0.035

Analysis and Quantification from to spectral mapping data with slight differences in the staining state of the biotissue.

● SR-5100HM optional accessories



● ZV-60 MS-ADAPTER

It is the adapter for connecting the microscope and C-mount port.



● ZV-57 / ZV-58 MS-CORRECT

Spectral transmission factor correction tool for microscope lens.

- Light source : Halogen lamp
- Lamp life : Approx. 700 hours
- Operating conditions : Temperature 0 to 40°C
Humidity 20 to 80%R.H. (No condensation)
- Dimensions : Light unit : 115x130x281 mm
Diffuser unit : 109x29x62 mm
Light guide length : 1 m
- Power supply : ZV-57(AC 100 to 120V)
ZV-58(AC 200 to 220V)



● ZV-61 LENS-CORRECT

Spectral transmission factor correction tool for zoom lens.

- Operating conditions : Temperature 0 to 40°C
Humidity 20 to 80%R.H. (No condensation)
- Dimensions : Light unit : 97x245x110 mm
Diffuser unit : 223x212x19mm
Light guide length : 2 m
- Power supply : AC 100 to 240V

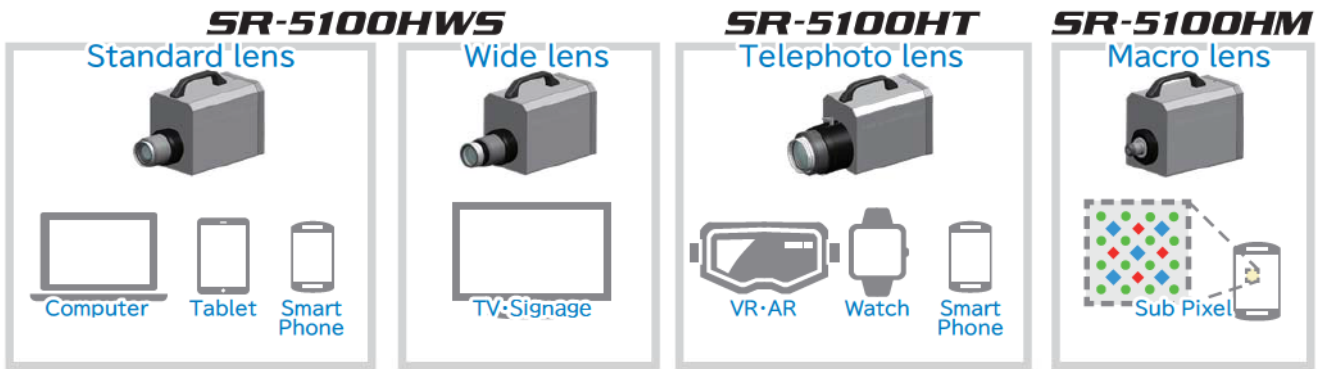

SDK (Software Development Kit)

Development kit is composed of header file and library to control SR-5100 through a network Computer.

It is possible to create customized software according to external communication and the needs of user.

It can acquire and display only the necessary data, and it is also possible to reduce the file size of measurement data.

Sample program is also included.

Dimension

SR-5100HWS Standard lens

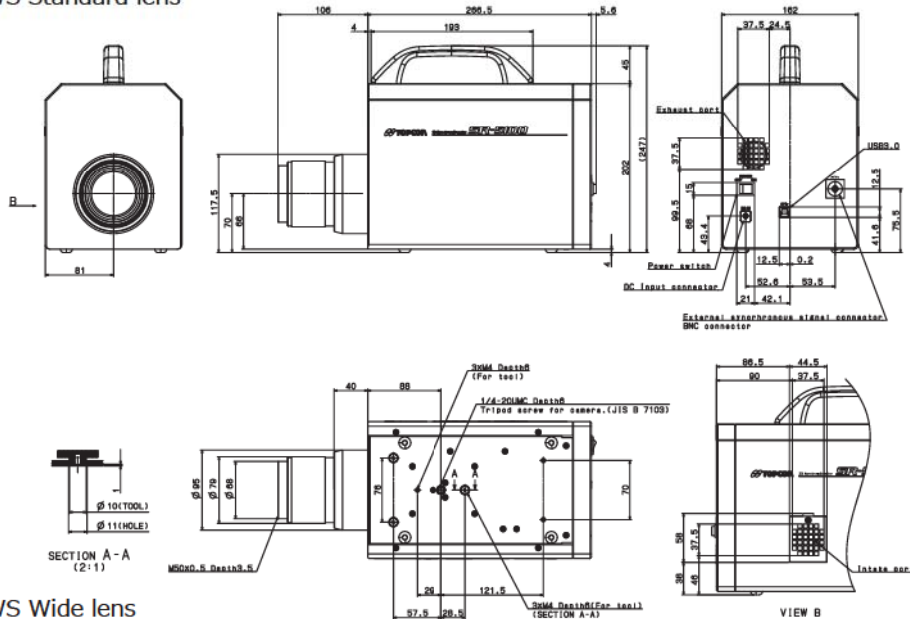

SR-5100HWS Wide lens

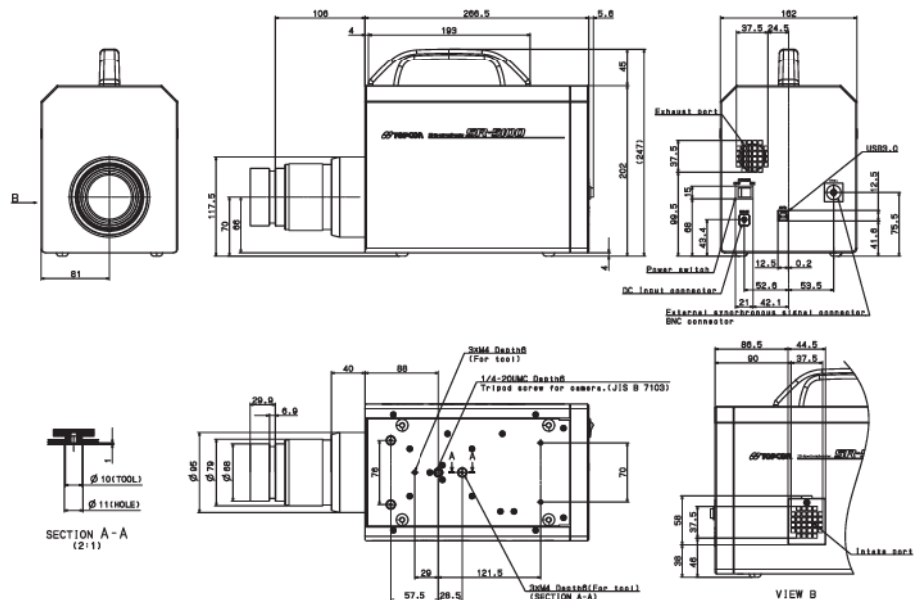

System diagram

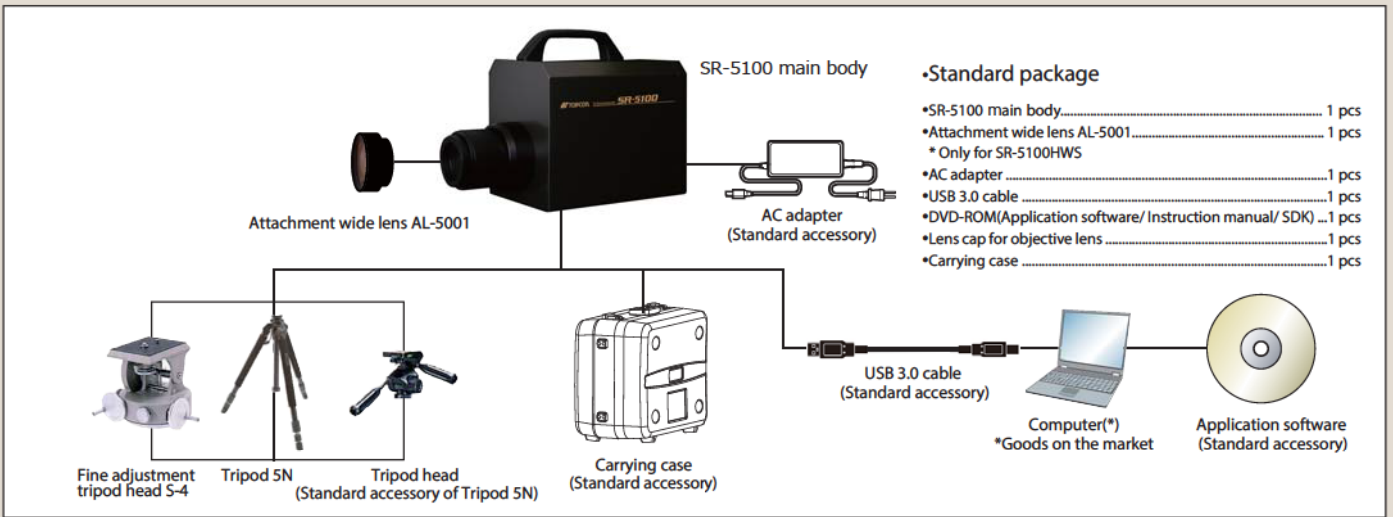

Optional accessories



• Tripod 5N

Easy collimation of measurement object.

- Max height: 1835 mm
- Min height: 585 mm
- Folder length: 810 mm
- Leg section: 3 steps
- Weight: Approx. 4.8kg including Tripod head



• Fine adjustment stand S-4

It is easy collimation each direction up / down / left / right by removing the tripod 5N head and installing this unit.

- Elevation angle: 40°
- Depression angle: 80°
- Rotation: 360°
- Weight: Approx. 1.7kg

SR-5100HT

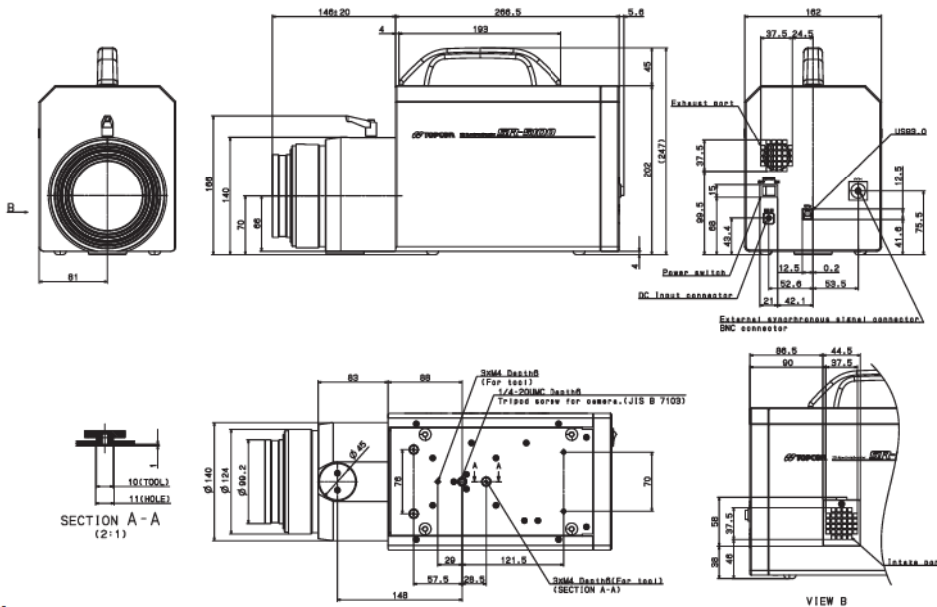

SR-5100HM

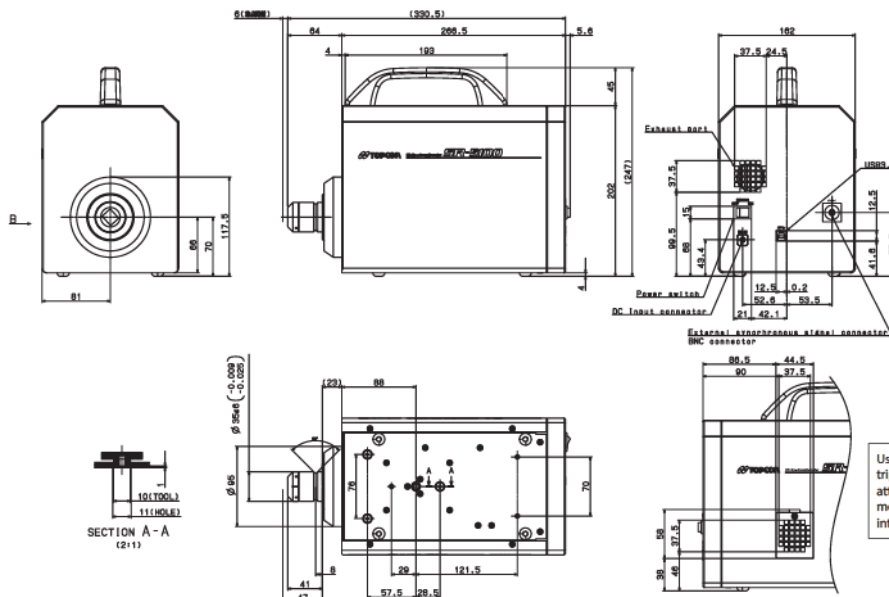

Use only specified screws when using the tripod screw and screw holes for jig attachment. Do not tighten the screws any more than necessary. Doing so might cause internal breakage.

Unit : mm

Specification

	SR-5100HWS		SR-5100HT		SR-5100HM		
Measurement mode	Spectral Mode	XYZ(Filter) Mode	Spectral Mode	XYZ(Filter) Mode	Spectral Mode	XYZ(Filter) Mode	
Detector	5 mega pixel CMOS image sensor						
Objective lens	Standard lens / Wide lens *1		Telephoto lens		Macro lens		
	Focal length		f=32mm / f=24mm		f=140mm		
Effective pixel	2448x2048						
Measurement range *2	0.5 - 17,000,000,000cd/m ²	0.005 - 100,000cd/m ²	0.5 - 17,000,000,000cd/m ²	0.005 - 100,000cd/m ²	0.5 - 17,000,000,000cd/m ²	0.005 - 100,000cd/m ²	
Wavelength range *3	380~780nm	-	380~780nm	-	380~780nm	-	
Spectral accuracy *4	±0.5nm	-	±0.5nm	-	±0.5nm	-	
Spectral bandwidth *5	7nm	-	7nm	-	7nm	-	
Wavelength resolution	1nm	-	1nm	-	1nm	-	
Linearity	Luminance *3,*6	±2%	±3.5% (≤0.01cd/m ²) ±3% (0.01cd/m ² <)	±2%	±3.5% (≤0.01cd/m ²) ±3% (0.01cd/m ² <)	±2%	±3.5% (≤0.01cd/m ²) ±3% (0.01cd/m ² <)
		Chromaticity *3,*6	±0.0035 (≤1cd/m ²) ±0.0025 (1cd/m ² <)	±0.0085 (≤0.01cd/m ²) ±0.0050 (≤0.05cd/m ²) ±0.0030 (0.05cd/m ² <)	±0.0035 (≤1cd/m ²) ±0.0030 (1cd/m ² <)	±0.0090 (≤0.01cd/m ²) ±0.0050 (≤0.05cd/m ²) ±0.0030 (0.05cd/m ² <)	±0.0035 (≤1cd/m ²) ±0.0025 (1cd/m ² <)
	*6,*9		±0.005	±0.008	±0.005	±0.008	±0.005
In-plane uniformity *10	Luminance: ±2% / Chromaticity: ±0.003						
Repeatability	*3,*6,*7	0.6% (≤1cd/m ²) 0.5% (1cd/m ² <)	0.70% (≤0.01cd/m ²) 0.35% (0.01cd/m ² <)	0.8% (≤1cd/m ²) 0.5% (1cd/m ² <)	0.90% (≤0.01cd/m ²) 0.35% (0.01cd/m ² <)	0.6% (≤1cd/m ²) 0.5% (1cd/m ² <)	0.70% (≤0.01cd/m ²) 0.35% (0.01cd/m ² <)
		*3,*6,*8	0.003 (≤1cd/m ²) 0.002 (1cd/m ² <)	0.006 (≤0.01cd/m ²) 0.004 (≤0.05cd/m ² <) 0.002 (0.05cd/m ² <)	0.004 (≤1cd/m ²) 0.003 (1cd/m ² <)	0.009 (≤0.01cd/m ²) 0.004 (≤0.05cd/m ² <) 0.002 (0.05cd/m ² <)	0.003 (≤1cd/m ²) 0.002 (1cd/m ² <)
	Interface						
	USB3.0 / External trigger						
Power supply							
AC100 - 240V (50/60Hz) Dedicated AC adapter							
Power consumption							
Approx. 20W							
Operation condition							
Temperature: 0 to 35°C, Humidity: 80%R.H. or less (No condensation)							
External dimension			W162xH247xD402.4mm *1		W162xH247xD330.5mm		
Weight			Approx.6.3Kg		Approx.8.2kg		
					Approx.5.8kg		

*1:Standard lens + Attachment lens, *2:Standard illuminant A, *3:Standard illuminant A, *4:Hg, Hi precision mode, *5:FWHM, Hi precision mode,

*6:At the center of sensor, *7 Within 2σ, *8:Max value - Min value, *9:Standard illuminant A + our standard colored glass filters, *10:Center of the sensor, Standard illuminant A, within 80% of field of view,

Measurement area: Standard lens

Measurement distance (mm)	400	500	1,000	1,500	2,000	2,500
Horizontal (mm)	178.0	221.5	435.9	649.7	866.2	1072.5
Vertical (mm)	148.9	185.3	364.7	543.5	724.7	897.2

Measurement area: Wide lens

Measurement distance (mm)	400	500	1,000	1,500	2,000	2,500
Horizontal (mm)	246.6	303.0	587.5	869.9	1155.0	1437.5
Vertical (mm)	206.3	253.5	491.5	727.8	966.2	1202.7

Measurement area: Telephoto lens

Measurement distance (mm)	600	1,000	1,500	2,000	2,500
Horizontal (mm)	60.5	108.6	168.9	229.0	288.7
Vertical (mm)	50.6	90.9	141.3	191.6	241.6

Measurement area: Macro lens

Measurement distance (mm)	6
Horizontal (mm)	6.8
Vertical (mm)	5.7

*Above values are design specifications. Above values may be difference from the values in practice.

*The measurement distance is from tip of objective lens to the measurement target.

*Above values are 80 % area of FOV.

Hardware requirement

OS	Windows* 10 Pro (64bit)
CPU	Intel® Core(TM) i7-4770 or higher
Memory	16GB以上
HDD	500GB or higher More than 3GB free space is necessary in the system drive (that is a drive where OS is installed). If full size measurement is executed, data size of its result is about 8GB.
USB port	USB3.0 : 1 port *Please use USB port on the mother board (In case of laptop PC, use USB port on the main body). *Otherwise it may cause malfunction.
USB Host Controller	Intel® USB 3.0 eXtensible Host Controller
USB driver	Microsoft Windows® 10 USB 3.0 driver *Windows® 10 has a native in-box USB 3.0 driver.
Display	1920*1080 or higher, 16.77 million colors (32bit) or higher
Drive	DVD-ROM drive

*Microsoft and Windows are registered trademark of Microsoft Corp. in the US and other countries.

*Intel Core is a registered trademark or trademark of Intel Corporation in the US and other countries.

*All other company and product names listed in this sheet are trademarks or registered trademarks of their respective companies.

*This specification is based on the test environment of Topcon Technohouse. Incompatibility problem with individual PC is out of warranty.



*Some screens are simulated.

*The specifications and external appearances of product in this catalogue may be changed without prior notice due to improvements.

*The catalogue includes products that are sold separately.

*The actual color of products may differ slightly from the catalogue due to lighting and printing conditions.

Contact information:

TOPCON TECHNOHOUSE CORPORATION

75-1 Hasunuma-cho, Itabashi-ku, Tokyo 174-8580 JAPAN

Phone: +81-3-3558-2666 Fax: +81-3-3558-4661

E-mail: techno-info@topcon.co.jp

SAFETY PRECAUTIONS

- Make sure to carefully read the "Manual" to ensure that you use the product properly and safely.
- Always connect the instrument to the specified power supply voltage. Improper connection may cause a fire or electric shock.
- Be sure to use the specified batteries.
- Using improper batteries may cause a fire or electric shock.

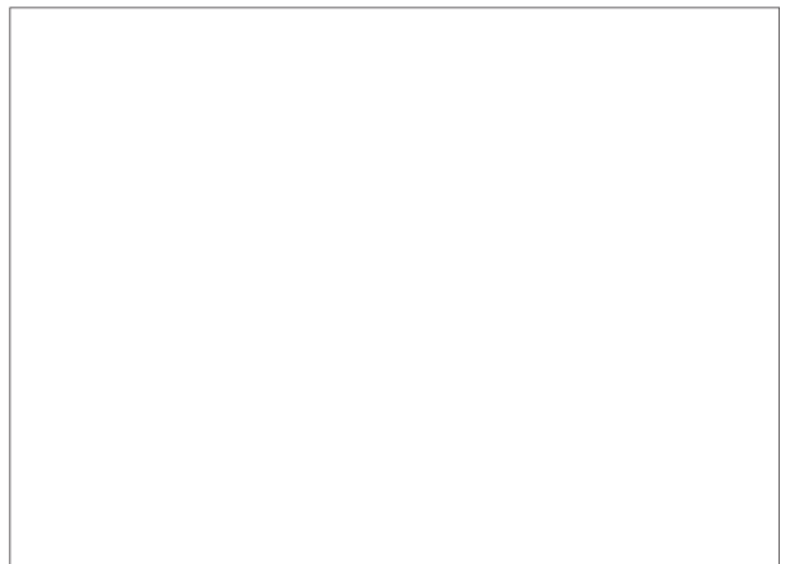

For more information please visit our website.

<http://www.topcon-techno.co.jp/en/>

