



Torque Dynamometer

Torque and Speed Measurement

Controller **DM5001**
HB-N Series Dynamometers

Automotive motors
Home appliance motors
Industrial automation motors

DC motors
BLDC motors
AC motors
SR motors
Stepping motors

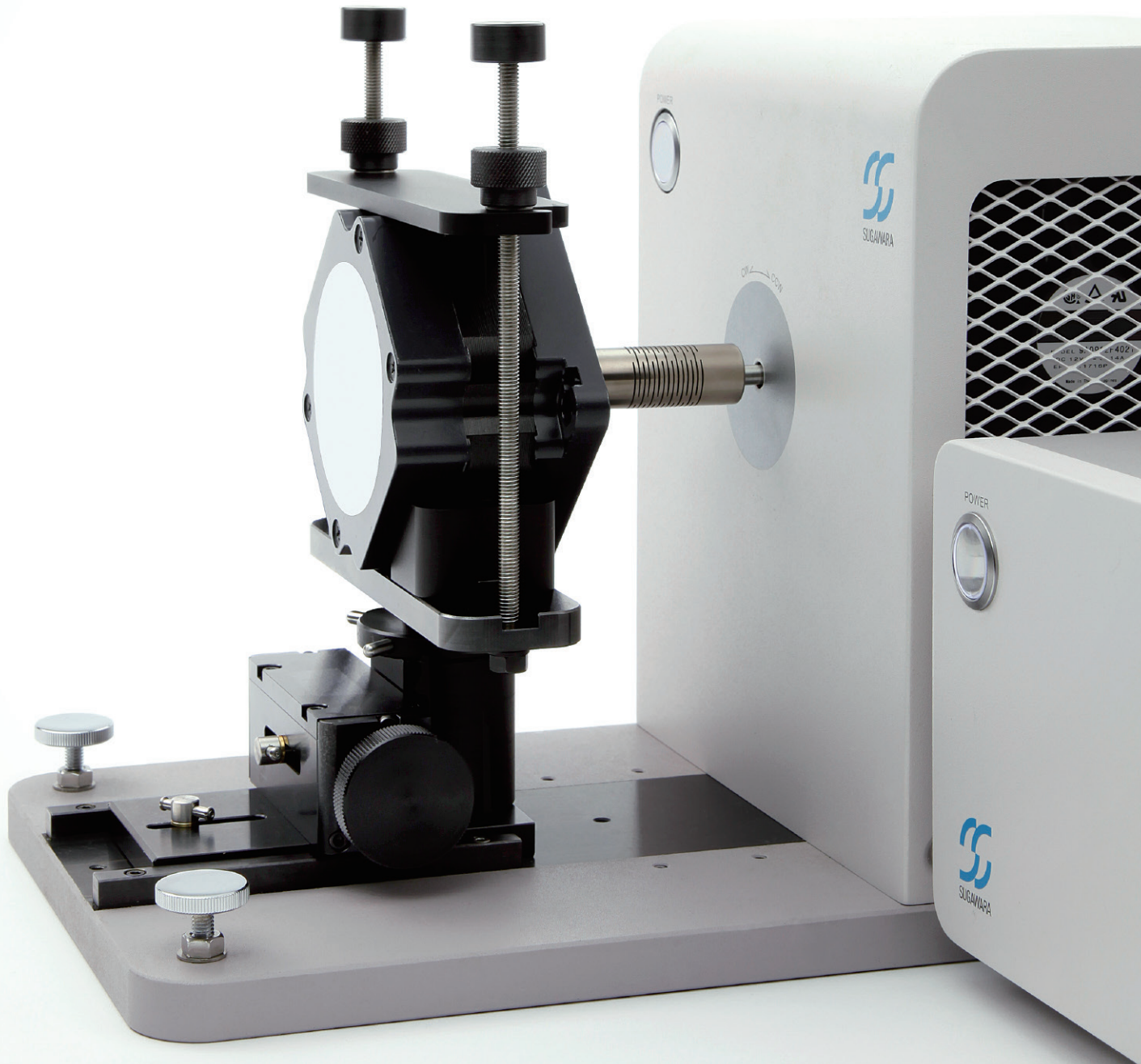

Torque accuracy : $\pm 0.1\%$

- Rotation speed accuracy : $\pm 0.01\%$
- Maximum rotation speed : 60,000 r/min

**Dynamometer using a reliable hysteresis brake
with superb reproducibility unaffected by inertia
Improved measurement accuracy and ease of use**

**Expanded lineup of convenient functions
and strong production-line/development-bench support**

- Simple start-up without the need for PID settings
- Simple torque calibration on personal computer screen
- Simultaneous measurement of temperature, flow rate, etc. by adding an I/O option
- Four measurement units can be connected with a single controller
- Endurance tests along time axis enabled by evolved measurement modes

**Sugawara's torque dynamometers
use hysteresis brakes.**

A hysteresis brake is a high-performance brake used in dynamometers to achieve high measurement accuracy. It generates a stable load torque according to the strength of the excitation current regardless of rotation speed.

■ Hysteresis brake features

- High-accuracy control
- Maximum rotation speed: 60,000 r/min
Stable load control from low-speed to high-speed rotation
* Maximum rotation speed depends on torque rating and model.
- Structure that minimizes the inertia moment of the rotor
- Long life owing to a non-contact brake
- Excellent thermal properties—torque not easily affected by temperature rise in the brake or surroundings
- Compact configuration compared with motor brakes

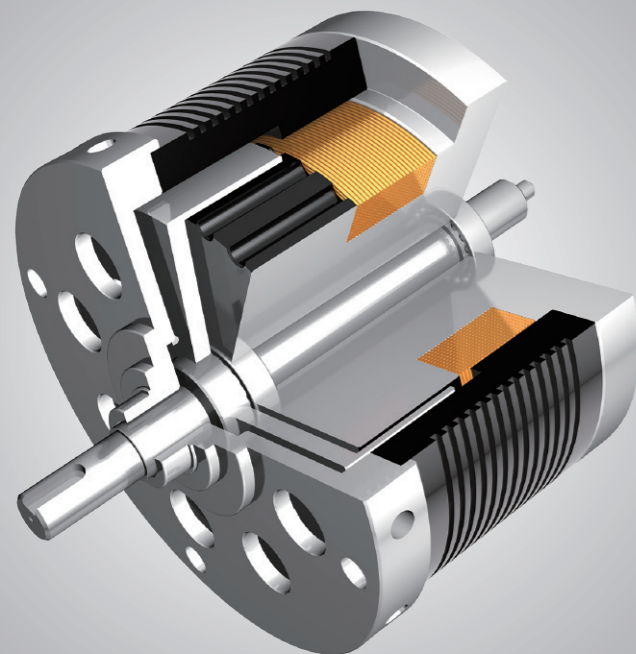

■ Hysteresis brake principles

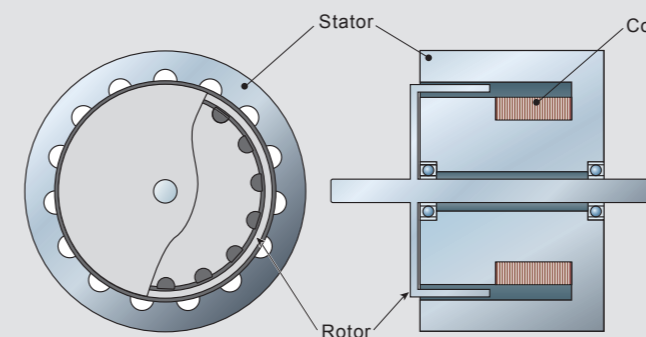

Hysteresis brake structure

A hysteresis brake is structured to rotate a rotor made of high permeability magnetic material inside an air gap containing a magnetic field formed by a cog-wheel-shaped stator. The magnetic flux flowing in the stator passes through the rotor, creating magnetic friction between the rotor and the stator, and acting as a non-contacting brake. This magnetic friction is proportional to the strength of the magnetic flux penetrating the rotor, and the strength of this magnetic flux can be adjusted by changing the strength of the exciting current applied to the coil. Therefore, a hysteresis brake makes it easy to adjust the braking force regardless of the rotation speed of the rotor.

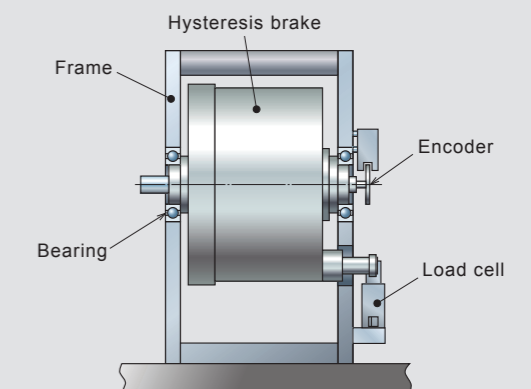

Torque detector structure

The brakes of HB-N series dynamometers are supported by bearings on the equipment frame. When the rotor is rotated by the motor under measurement and braked by magnetic friction with the stator, a reaction force is generated on the stator and the stator tries to rotate. This reaction force is detected by a load cell as the brake torque. Since the rotational moment acting on the stator is detected in an extremely static fashion, it is less susceptible to vibration than methods that involve detecting torque on a rotating shaft, and results in a stable detection method that is suitable for high-speed rotation.

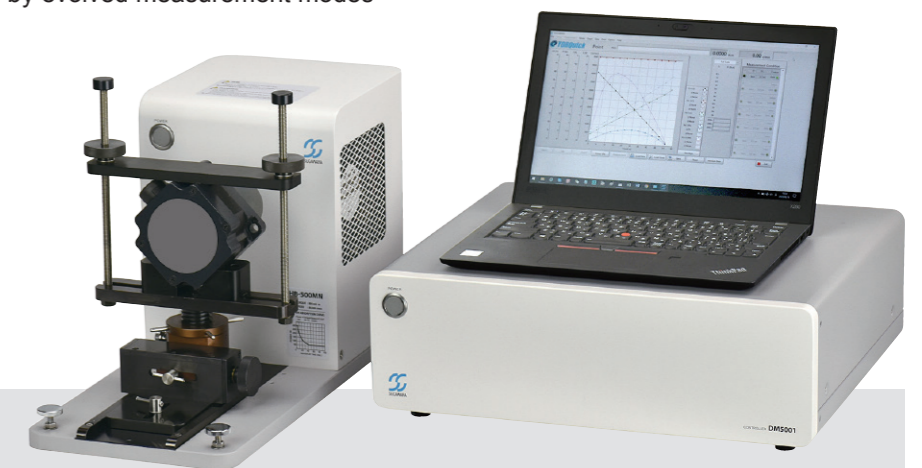

DM5001 Controller



The DM5001 controller for the HB-N series dynamometers demonstrates outstanding performance in combination with TORQuick specialized software.

■ Main features

- **Four HB-N Series dynamometers can be connected with a single controller.**
- **Analog torque and rotation speed outputs provided as standard**
- **Diverse expanded functions by adding an I/O option**
Connections can be made with external equipments enabling a variety of expanded functions.
- ▶ **Simultaneous measurement of voltage signal inputs from external sensors**
Using an analog 4 ch input (0–10 V), it is possible to simultaneously measure and store voltage inputs from external sensors such as temperature and flow rate sensors. The scaling and unit of these inputs are user-configurable. These input data can be plotted simultaneously on a graph of torque measurements, and can also be configured as pass/fail judgment criteria.
- ▶ **Controls an external motor power supply**
This function allows you to switch a motor's power supply on and off (via contact inputs). Also, if you use a power supply that has an analog input function, the analog voltage output function allows you to change the power supply voltage during the measurement sequence.



I/O Option
*Please specify I/O options when ordering DM5001.

■ Specifications

Analog output	
Torque analog output	Max ±10 VDC ±1% Voltage and torque are individually configurable
Speed analog output	Max ±10 VDC ±1% Voltage and speed are individually configurable
I/O option (Optional)	Digital input 4 ch, Digital output 4 ch Analog input 4 ch, Analog output 2 ch Contact output for power supply control (NO, NC) 1 ch
Interface	USB 2.0 or greater (Type A)
Temperatures	0–40°C
Humidity	20–90%RH, without dew condensation
Power	100–240 VAC±10%, 50/60 Hz
Power consumption	30 VA or less
Dimensions	W×H×D 430×148×360 mm
Weight	8 kg

Input power measurement compatible with diverse power meters

You can choose a suitable one according to your application such as single-phase AC/DC motors and inverter motors.

Yokogawa

Precision Power Analyzer WT5000 (*1)
High performance Power Analyzers WT1800/WT1800E Series
Digital Power Meter WT300E Series



WT5000

HIOKI

Power Analyzer PW3390
Power Meter PW3335/3336/3337



PW3390

*1 Select WT1800E from the command type settings of WT5000. A maximum of 6 elements can be used.

Motor Evaluation Software



TORQuick software for motor evaluation is developed with the user in mind. It can measure a variety of motor speed/torque characteristics in combination with a torque dynamometer and can manage and store data on Windows. Its user-friendly, highly sophisticated interface enables high-accuracy measurements through simple operations.

■ Main features

● User-friendly graphical user interface

The graph displays 5 axes × 3 items in real time. We have improved the operability of this display by adding a graph axis auto setting function. You can also customize the graph line style and dot appearance.

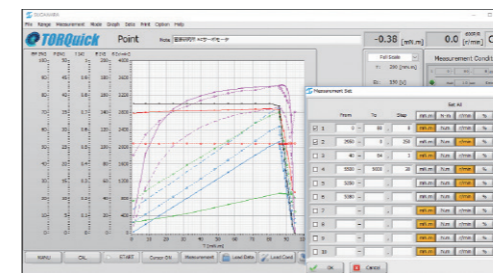

It is also easy to change the power analyzer settings in the software.

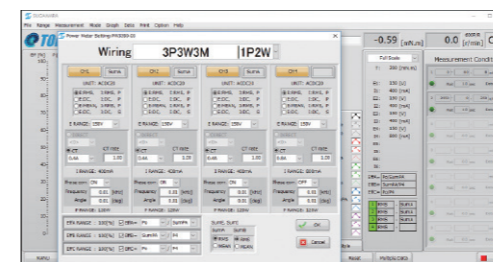

● Automatically recognizes the models of the connected dynamometers

● More than 60 measurement items

Torque / Rotation speed / Time / Output power / Direction of rotation / Voltage / Current / Efficiency / Power factor / Voltage frequency / Current frequency etc.

■ Operating conditions

OS	Windows 10 (64 bit) Professional Japanese or English version
CPU	Intel Core i5 or later processor
Memory	8 GB or more recommended
HDD	256 GB or more recommended
Monitor	HD FWXGA 1366×768 or greater
DVD drive	One or more units (required for software installation)
Com. Ports	USB port × 2

● Diverse measurement modes according to use

▶ High accuracy point mode with simple settings

S-T characteristics (rotation speed–torque characteristics) can be measured by simply setting measurement points. Torque control, rotation-speed control, and brake control can be combined within one measurement. The data is not affected by moment of inertia because it measures values at stable operating points. Extrapolation function can also be used to determine no-load and stall points from measured data and display them on a graph.

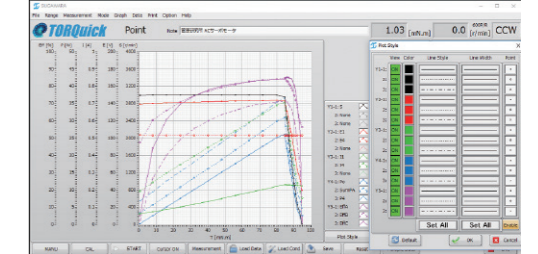

▶ Sequence mode with support for various types of measurement

By controlling the torque, rotation speed and braking over time, it is possible to perform various tests such as sweep measurements, endurance tests and cycle tests. This makes it possible to perform load simulations based on actual use conditions, and durability tests that combine test conditions and idling conditions and repeat it up to 10,000 cycles.

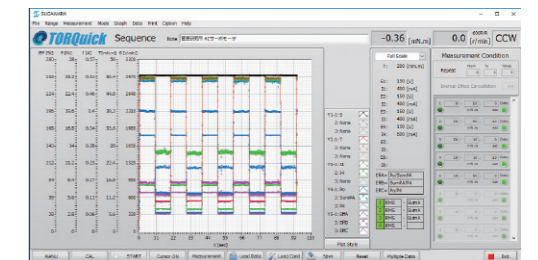

▶ Inspection mode specialized for pass/fail testing

Pass/fail testing can be performed by setting the upper and lower limits for up to five measurement items based on torque, rotation speed or braking. By specifying a file name in advance, you can automatically generate a file listing the time, sequence number and results of each measurement.

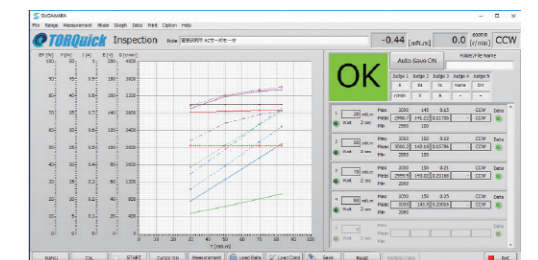

▶ Manual mode where measured values are displayed in real time

In this mode, you can set and control the torque, rotation speed or braking at a single point, and display all the corresponding measured values in real time. This mode can be used for simple behavior observations and for the measurement of starting torque.

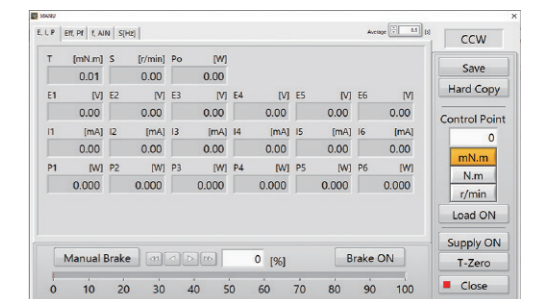

HB-N Series Dynamometers



■ Main features

● Adopts a high-reliability hysteresis brake

The hysteresis brake used here has a long track record of high reliability due to an original structure developed by Sugawara. This structure improves torque control performance and reduces vibration during rotation by narrowing the gap between the rotor and stator and minimizing the inertia moment of the rotor.

● Measurement accuracy at industry's highest level

Torque accuracy is ±0.1% of the rated torque in all models.*1

● Stable measurement from low-speed to high-speed rotation

Stable measurements can be performed from low-speed to high-speed rotation regions because it detects torque from the force of movement of the brake's stator. The maximum rotation speed is 60,000 r/min (rotation speed differs according to torque rating). An optional rotary encoder for the measurement of extremely low speeds supports 10–10,000 r/min (600 P/R) and 5–5,000 r/min (1200 P/R).

● Extensive product lineup with torque ratings from 5 mN·m to 50 N·m

13 models of dynamometers to choose from according to motor power for making high-accuracy measurements

● Features air bearings for low-torque models

● Short-plate models and temperature chamber models are provided as standard.

■ Calibration

Calibration is necessary for measuring correct torque values. A separately sold calibration jig set (calibration bar and weight) is used for this purpose. The calibration bar is attached to the shaft and the weight is suspended from the end of the bar. Calibration is achieved by simply pushing the CAL button. No volume adjustments are necessary.

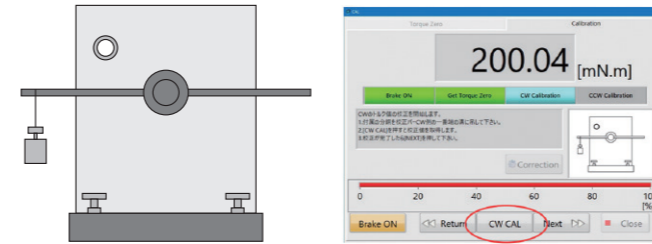

■ MMJ-series motor mounting jigs

MMJ-series motor mounting jigs have an adjustment function for centering the motor and measurement shafts. Four models are available for twelve measurement units ranging from HB-5MN to HB-20N.

Since the surface of the V block of MMJ on which the motor under test is placed is designed to be parallel with the shaft of the dynamometer, the shafts of the motor and dynamometer will be parallel when they are simply mounted on the V block if the motor body and the shaft are parallel. As a result, alignment is easy to achieve.

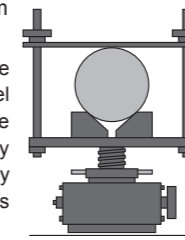

■ Safety cover

In certain cases, for example, when shaft alignment is performed incorrectly, the coupling may be damaged during measurement, causing it to fly off in random directions and leading to injury. Always implement adequate safety measures (e.g., attaching a safety cover). A safety cover is available from Sugawara (option).

■ Power absorption curve

The allowable time for continuous loading of the dynamometer varies with the power it absorbs. The dynamometers must be used correctly according to the following graphs of power absorption curve. Contact us for the graphs of other models.

Continuous use beyond the limit indicated in the graphs will make it difficult to obtain correct data and may cause damage.

For models greater than the HB-2N, the brake current is automatically cut off to set the brake torque zero when the absorption power exceeds the limit.

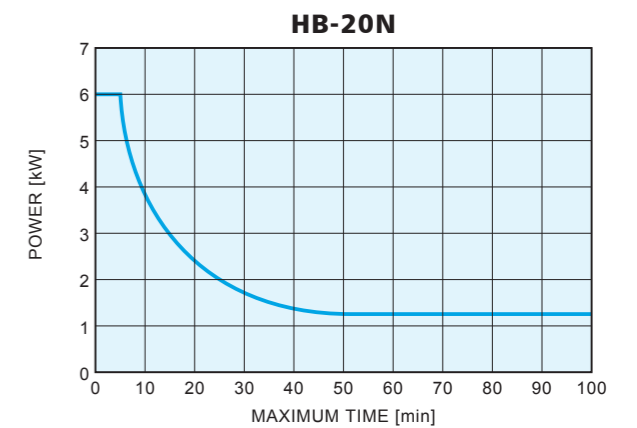
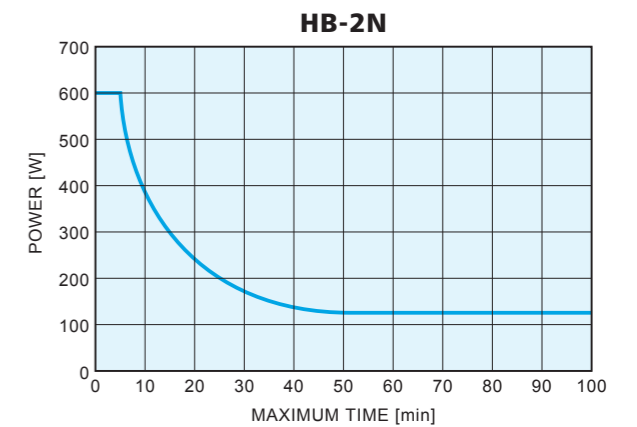
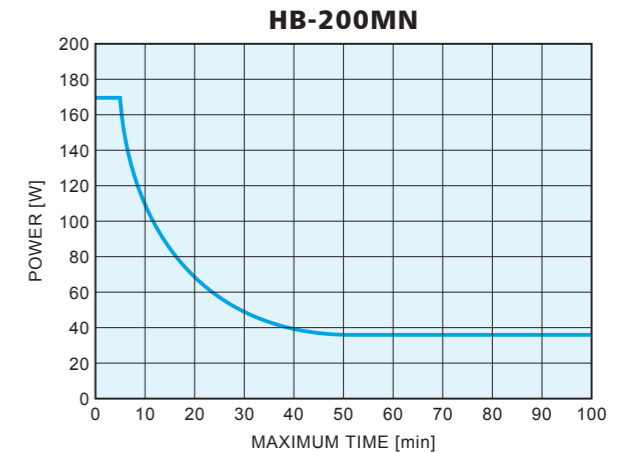

■ Dynamometer Specifications

Models	HB-5MN	HB-10MN	HB-20MN	HB-50MN	HB-100MN	HB-200MN	HB-500MN	HB-1N	HB-2N	HB-5N	HB-10N	HB-20N	HB-50N	
Torque rating	5 mN·m	10 mN·m	20 mN·m	50 mN·m	100 mN·m	200 mN·m	500 mN·m	1 N·m	2 N·m	5 N·m	10 N·m	20 N·m	50 N·m	
Torque detection	Brake-stator reaction force detected by strain-gauge load cell													
Torque accuracy	±0.1% of full scale (accuracy of the system including DM5001 Controller, after calibration)*1													
Max. rotation speed	40,000 r/min			60,000 r/min			50,000 r/min	30,000 r/min	25,000 r/min	20,000 r/min	12,000 r/min	7,000 r/min		
Rotation speed detection	Optical rotary encoder of 60 P/R (standard models)*2													
Rotation speed accuracy	±0.01%													
Power rating (5 min)	7.5 W	15 W	30 W	75 W	120 W	170 W	300 W	400 W	600 W	1.5 kW	3.0 kW	6.0 kW	12 kW *3	
Power rating (continuous)	1.5 W	3 W	6 W	15 W	25 W	35 W	60 W	80 W	120 W	0.3 kW	0.7 kW	1.2 kW	4 kW	
Brake	Hysteresis brake													
Brake support	Air bearings			Ball bearings										
Brake rotor moment of inertia kg · m ²	0.6×10 ⁻⁶	0.8×10 ⁻⁶	1.0×10 ⁻⁶	2.6×10 ⁻⁶	3.9×10 ⁻⁶	9.2×10 ⁻⁶	2.8×10 ⁻⁵	1.9×10 ⁻⁴	0.5×10 ⁻³	1.8×10 ⁻³	6.3×10 ⁻³	2.1×10 ⁻²	6.1×10 ⁻²	
Brake cooling	—						Air cooling by fan					Cooling by fan and blower		
Dimensions W×H×D mm	210×246×400						210×276×500		300×325×600		500×500 ×1000	500×537 ×1245	550×1300 ×1300	
Weight	18 kg			20 kg			26 kg	29 kg	56 kg	63 kg	180 kg	210 kg	500 kg	
Power	100–240 VAC								100 VAC		3 Phase 200/220 VAC			
Power consumption	30 VA or less								200 VA or less		1 kVA or less			
Shaft diameter	φ3		φ4	φ6			φ10	φ12	φ15	φ18	φ20	φ30		
Shaft shape	Round				D-cut				Key seat					
Shaft height	130 mm				160 mm				200 mm		230 mm		250 mm	
Standard motor jig	MMJ-7C				MMJ-9C				MMJ-10C		MMJ-12B		Customization available	
Diameter of attachable motor	φ 25–100 mm				φ 50–150 mm				φ 60–180 mm		φ 40–200 mm			

*1: After calibration with the DM5001 controller. Torque accuracy is ±0.25% for 1200 P/R optional models of HB-500MN, HB-1N, HB-2N, and HB-5N.

*2: All the models have two kinds of low-speed encoder options, 600P/R type (10–10,000 r/min) and 1200P/R type (5–5,000 r/min).

*3: Power rating (3 min) for HB-50N

Power (Motor output power) is calculated as follows.

$$\text{Power [W]} = \text{Torque [N·m]} \times \text{Rotation speed [r/min]} \times 0.1047$$

Option

Optional items for DM5001

Software	DVD-TORQUICK	Software for motor evaluation
I/O option	77RG-K001	Connector for external input/output
Terminal block for I/O option	8TC1-M37	Screw-type terminals, 37 poles
Terminal block cable for I/O option	8CN-S01-202	D-sub37pin - D-sub37pin, 2 m (1 m available)
Discrete-wire cable for I/O option	8CN-L01-202	D-sub37pin - Discrete-wire, 2 m (1 m available)
BNC cable	8CT-401-202	For Rotation speed/Torque analog output, 2 m (1 m available)
HB connection cable	8CM-C01-202	2 m (1/5/7/10 m available)
Power cable	1C1-002	2 m, 100-110 VAC (Japan) (PSE)
Power cable	8CV-614-202	2 m, 200-240 VAC (China) (CCC)
Power cable	8CU-604-202	2 m, 200-240 VAC (EU/Korea) (KC)
Rack mounting bracket	RKJ-DMC01 (JIS)	RKE-DMC01 (EIA)

Optional items for HB-N series

Short base plate type	HB-*NS	Supports HB-50MN - HB-5N
Temperature chamber type	HB-*NT	Supports HB-50MN - HB-5N
Change of speed encoder	HB-*Ne6	600 P/R (10-10,000 r/min) (not available on HB-50N)
Change of speed encoder	HB-*Ne12	1200 P/R (5-5,000 r/min)
Calibration jig set	CJ-HB-*N	Includes calibration bar and weight, supplied in a wood case
Safety cover	TBSC-*C	(HBCC-1*01 for HB-2N or greater)
Power cable	1C1-002	2 m 100-110 VAC (Japan) (PSE)
Power cable	8CV-614-202	2 m 200-240 VAC (China) (CCC)
Power cable	8CU-604-202	2 m 200-240 VAC (EU/Korea) (KC)
Power cable	8CT-620-202	For HB-10N 100-110 VAC
Power cable	8CT-614-202	For HB-20N 100 VAC Round connector - 3P plug

•Safety cover for HB-50N can be custom-made.

Coupling

Product lineup includes small diameter types with low inertia.
Customized coupling attachments that support special shaft shapes are also available.

Dynamometer	Rotation speed			
	30,000 r/min or less	40,000 r/min or less	50,000 r/min or less	60,000 r/min or less
HB-5MN	Sugawara, RC-2.2- * -6	Nabeya Bi-tech, XHW-C Series	—	—
HB-10MN	Sugawara, RC-2.2- * -10		—	—
HB-20MN	Sugawara, RC-2.2- * -13		—	—
HB-50MN	Sugawara, RC-3.2- * -10 Sugawara, RC-3.2- * -13	Nabeya Bi-tech, XHW-C, MST-C Series MIGHTY, MK2 Series		MIGHTY, MK2 Series
HB-100MN	Nabeya Bi-tech, XHW-C Series		MIGHTY, MK2 Series	
HB-200MN	MIGHTY, MK2 Series			
HB-500MN	Nabeya Bi-tech, XHW-C Series MIGHTY, MK2 Series	MIGHTY, MK2 series		—
	10,000 r/min or less	20,000 r/min or less	25,000 r/min or less	30,000 r/min or less
HB-1N	Nabeya Bi-tech, XHW-C, MJT-C Series			Nabeya Bi-tech, MJT-C Series
HB-2N	Nabeya Bi-tech, XGT2-C Series			—
HB-5N	Nabeya Bi-tech, XGT2-C Series	Nabeya Bi-tech, MJT-C Series	—	—
	7,000 r/min or less		10,000 r/min or less	12,000 r/min or less
HB-10N	Nabeya Bi-tech, XGT2-C, MJT-C Series			
HB-20N				
HB-50N	Nabeya Bi-tech, MJT-C Series Miki Pulley, SFC Series	—	—	—

- When using RC-type rubber couplings, difference between coupling hole diameter and shaft diameter or length of fitting may cause slipping preventing application of load up to the maximum allowable torque.
- Coupling hole diameter supports dimensional tolerance h7 of the motor shaft diameter.
- MIGHTY CORPORATION coupling is available via special order (10,000 r/min or higher).
- Please feel free to ask about coupling choices.



Damage and scattering of the coupling during measurement may cause injury.
Always use the safety cover.

Danger

Data measurement services using Sugawara's motor testers are available.
Please visit our website for more information.

The above specifications are subject to change without prior notice for product improvement.

Products: Xenon Flash, Torque Dynamometers, Bearing Inspection Systems, etc.

SUGAWARA Laboratories Inc.



- Head office** | 8-2 Minami-Kurokawa, Asao-ku, Kawasaki-shi, Kanagawa, 215-0034, Japan
- Tokyo sales office** | Tel: +81-44-989-7320 Fax: +81-44-989-7338
- Osaka sales office** | 6-17 Yokomakura-Nishi, Higashiosaka-shi, Osaka, 578-0956, Japan
Tel: +81-72-966-1061 Fax: +81-72-966-0961
- Nagoya sales office** | 1-2-29 Kamimaezu, Naka-ku, Nagoya-shi, Aichi, 460-0013, Japan
Tel: +81-52-331-6562 Fax: +81-52-331-6604

URL: <https://www.sugawara-labs.co.jp/> E-mail: info@sugawara-labs.co.jp

