

2D Luminance Colorimeter **UA-200 / UA-200A**

Ultra low luminance measurement performance of the industry's top-level.

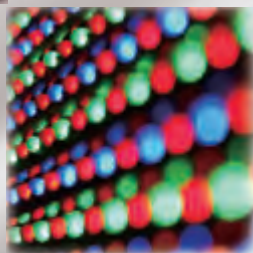

Enhanced and expanded software functions are best suitable to measure interior panel of automobile, flat panel display, and illumination.



Measuring the uniformity of luminance and chromaticity.

UA-200 series is suitable for use in the display, automotive, and illumination industries.

UA-200A

Ultra-low luminance measuring

- The UA-1000A covers wide luminance range from 0.005cd/m² to 1,000,000cd/m².

Accuracy: Luminance

0.005 - 1cd/m² : ±3.0%

1cd/m² or more : ±2.0%

Layer function

- It is the most suitable to measure for wide dynamic range as the head light and DRL. (Daytime Running Lamps)



High color accuracy

- Newly developed XYZ optical filter, whose sensitivity is highly similar to color-matching function, make it possible to achieve high color accuracy of within ±0.005^{*1}.

^{*1}Our specification LED panel of RGBW

±0.008^{**2} ^{**2}Standard illuminance A + Color filter.

±0.003 (1cd/m² or more), ±0.005 (0.005 to 1cd/m²) ^{**3}

^{**3}Chromaticity accuracy in Standard illuminance A.

1.4 mega pixel CCD

- 1376x1280 resolution.

UA-200

High color accuracy

- Newly developed XYZ optical filter, whose sensitivity is highly similar to color-matching function, make it possible to achieve high color accuracy of within ±0.008^{*1}.

^{*1}Standard illuminance A + Color filter.

±0.003 (1cd/m² or more), ±0.005 (0.05 to 1cd/m²) ^{**2}

^{**2}Chromaticity accuracy in Standard illuminance A.

Shortest measuring time is 1 second ^{**3}

- Optimal algorithm allows reducing measuring time. ^{**3}Luminance measuring only.

1.3 mega pixel CCD

- 1280x960 resolution.

Multi-area Correction

- Splitting into 64x64(Max.) area and applying correction factors to each area.

Frequency setting

- Even when measuring flashing light, you can obtain stable measured data by setting frequency. ^{**4} ^{**4}50 to 240Hz

Diagonal correction

- Correcting tilting image.
- Once you specify a tilting correction setting in a recipe, measured images in subsequent measuring are corrected automatically.

OK/NG judgment function

- It can be OK / NG judgment given in the judgment conditions area.

Arbitrary shape of measuring spot

- Measuring spot are selectable from polygon, square, and circle.
- Various types of Instrument panels and design displays can be measured flexibly.

SDK ^{**5} is standard option

^{**5}Software Development Kit

UA-200 can be controlled via user host PC.

• UA-CORE SDK (Standard accessory software)

Development kit is composed of header file and library to control UA-200 through a network PC

Providing required module to develop user software, you are able to create a network program (socket communication program) by calling library functions.

You can develop software without caring about communication program.

Two or more UA-200 on a network can be controlled simultaneously.

Multipoint extraction & measurement

- Specifying multipoint of bright region
-> Extracting bright points from specified area based on threshold value, and measuring them automatically.

Object color mode

L*a*b*, Hue-Chroma

- It can be displayed the object color value by calculating standard white board and actual measurement data.

Standard application software supports measuring and evaluation operation.

You can control the UA-200series and retrieve measured data, save data, convert measured data into image via PC. The application software conducts various types of data processing and data analyzing easily.

Two types software are available for your usage.

• Standard mode

Full functions are available including UA-200series control.

• View mode

Viewer software for viewing image data and analyzing measured data. Can analyze measured data without UA-200series.

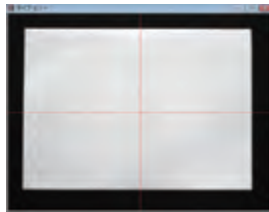

• Live view

Real time image show on PC. You can check and focus on a target via Live-view image. You can select a marker from cross target, diagonal marker, rectangle frame.



• Focusing assist

The ratio of focusing is displayed. You can refer to the ratio of focusing when focusing on a target.



• Optimizing area

Measuring condition is optimized at specified area.

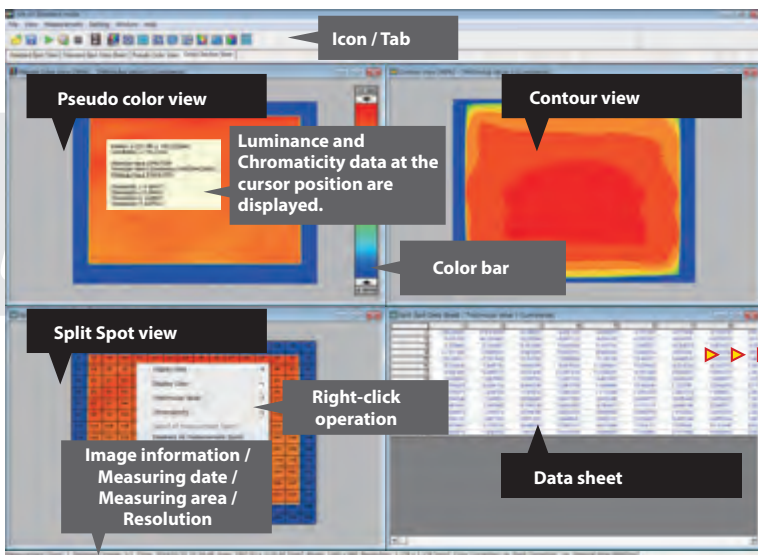

Measured data can be pasted to spreadsheet software

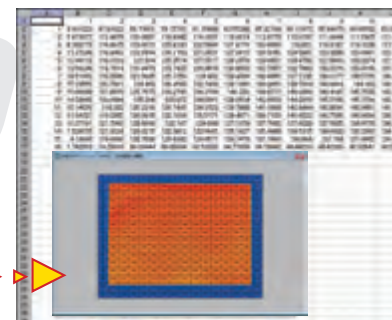

* Live view/Pseud color view / Split spot view / Standard spot view / Cross section view

Measured data in the each view * can be saved as CSV, txt, or image file (BMP/JPG/PNG). And can be pasted to spreadsheet software.

View mode



1.Pseudo color view/ Gray scale
Software-colored image and 16,384 steps gray scale present the difference in luminance / chromaticity on measuring area. This view is suitable for uniformity measuring.

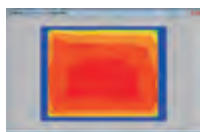

2.Contour view
This view use contour lines to indicate the profile of each tristimulus value.

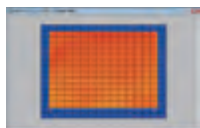

3.Split spot view
The Image divided with grid pattern shows in this view. Average value in the each divided area is calculated.

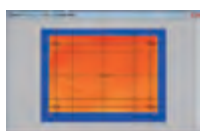

4.Standard spot view
Four type of Measuring standard available such as JEITA standard (EIAJ ED-2522/ ED-2710). You can customize the measuring spot size and the number of measuring spot.



5.Random spot view
Max 999 measuring spots can be placed on an image. Shape of measuring spots can be selected from Circle, Rectangle, Polygon (max 127 vertex).



6.Cross section view
Tristimulus value on the cross-section line is expressed as graph. The cross-section line are selectable from cross line or diagonal line(max.10 lines).



7.x,y/u',v' Chromaticity diagram view
Chromaticity value on the spot can be plotted on the x,y or u',v' diagram. The plotted diagram can be scaled up.



8.3D view
Tristimulus value on the measuring area is expressed as 3D.

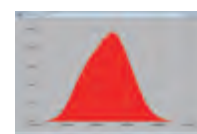

9.Histogram View
The statistical graphics indicates the frequency of occurrence in the vertical axis and the tristimulus value in the horizontal axis.

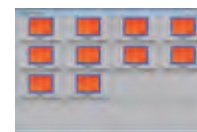

10.Thumbnail view
Image data with the number, measured date show as thumbnails.



11.Time-series graph view
The variation of measured data with lapse of time shows.



12.RGB view
Measurement object is displayed to be close to the actual color.

Optional Software

Evaluation program for Black Mura.

Black MURA

Evaluation program for Black Mura can analyze quality of the display corresponding to Black Mura standard of DFF's OEM working group.

This program can quantify black mura (Gradient: difference of the peripheral pixels) of the display for automobile and can judge OK or NG.

Evaluation for uniformity, gradient characteristics.

- Trimming of measurement area.
- Uniformity, gradient characteristics, Calculation of homogeneity.
- Judgement of OK or NG by threshold.

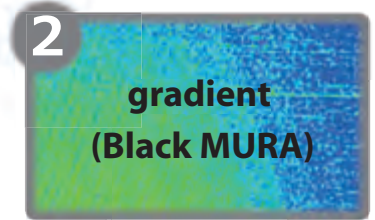

1. Luminance in white image.
2. Luminance in black image.
3. Luminance homogeneity in white image.
4. Luminance homogeneity in black image.
5. Absolute value of luminance. (Gradient in white image)
6. Absolute value of luminance. (Gradient in black image)
7. Relative value of luminance. (Gradient in white image/ white average)
8. Relative value of luminance. (Gradient in white image/ black average)
9. Relative value of luminance. (Gradient in black image/ white average)
10. Relative value of luminance. (Gradient in black image/ black average)

It is possible to save the item below by BMP or CSV format.

- [The center and four corner points]/
- [Calculation of resolution]
- [Numerical value of focus ratio]
- [Uniformity and gradient characteristics]

Evaluation of measurement equipment: It is possible to do a condition evaluation required for the standard.

1. Center and four corners comparison (Evaluation of measurement condition)

- Calculation of average luminance in the effective area.
- Comparison of average luminance on each area which is center and four corners.
- Judgement of OK or NG by threshold.

2. Calculation of resolution (Evaluation of measurement condition)

- Comparison between actual measurement value and the specification of sample resolution.
- Calculation of measurement equipment resolution.
- Judgement of OK or NG by threshold.

3. Calculation of focus (Evaluation of measurement condition)

- Actual measurement of white, black image and stripe image.
- Comparison between white and black image.
- Comparison between white stripe and black stripe image.
- Comparison luminance -> Calculation of focus.
- Judgement of OK or NG by threshold.

Usage

Evaluation of uniformity in luminance and chromaticity of LCD and LCD related materials, and OLED.

Evaluation of light distribution of interior panel of automotive and car audio.

Evaluation of uniformity in luminance and chromaticity of LED and OLED illumination.



Sample

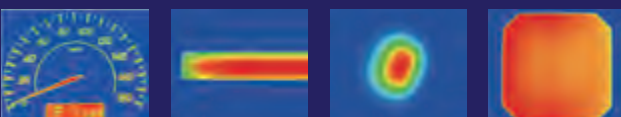

Automotive meter panel

Straight-tube type LED lamp

Bulb type LED lamp

OLED

Operating conditions

OS	Windows® 7 Ultimate (32bit/64bit)
	Windows® 7 Professional (32bit/64bit)
	Windows® 8.1 Pro (32bit/64bit)
	Windows® 10 Pro (32bit/64bit)
CPU	Intel® Core™ i5(Quad Core or higher) 2.8GHz or higher
Memory	4GB or more
HDD	1GB or more
LAN port	Giga Ethernet : 1port RS-232C serial or USB1.1 : another 1 port is required when using reference instrument for color correction.
Display	1,024x768 or more, 16,770,000 color (32bit) or more
Other	CD-ROM Drive

*Microsoft and Windows are registered trademark of Microsoft Corp. in the US and other countries.

*Intel® Core is a registered trademark or trademark of Intel Corporation in the US and other countries.

*All other company and product names listed in this sheet are trademarks or registered trademarks of their respective companies.

System diagram

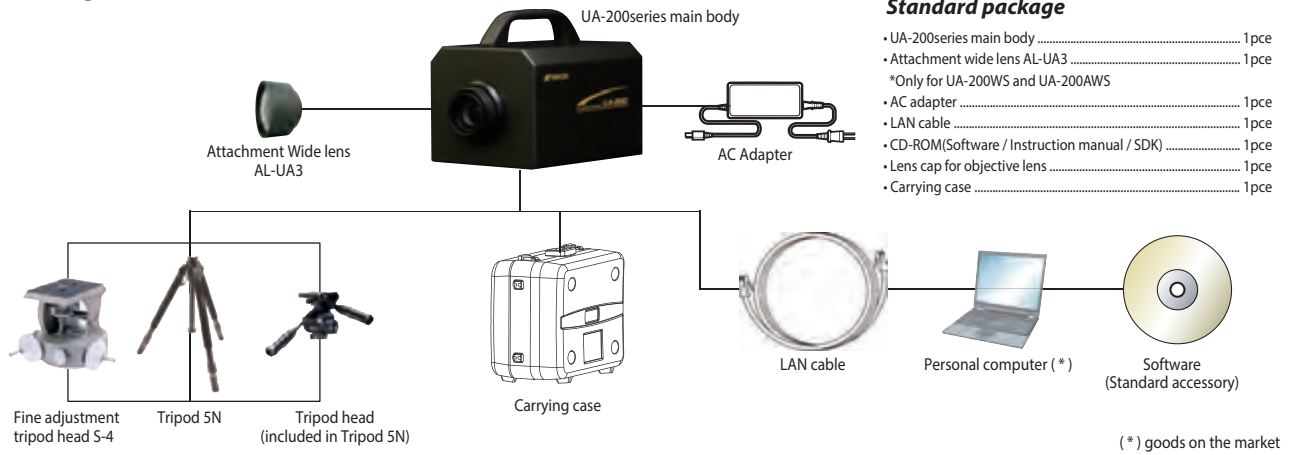

Standard package

- UA-200series main body 1pce
- Attachment wide lens AL-UA3 1pce
- *Only for UA-200WS and UA-200AWS
- AC adapter 1pce
- LAN cable 1pce
- CD-ROM(Software / Instruction manual / SDK) 1pce
- Lens cap for objective lens 1pce
- Carrying case 1pce

Optional accessories



• Tripod 5N

Simplifies collimation of measurement object.

- Max height: 1835mm
- Min height: 585mm
- Folder length: 810mm
- Leg section: 3steps
- Weight: About 4.8kg including Tripod stand

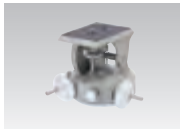

• Fine adjustment stand S-4

Simplifies vertical and lateral collimation.

- Elevation angle: 40°
- Depression angle: 80°
- Rotation: 360°
- Weight: About 1.7kg

• ND filter for telephoto type (10x / 100x)

The neutral density filter is for measurement of higher luminance than measurement range of UA-200T or UA-200AT. There are two filter. One is one-hundredth. The other one is one-tenth.

• Attachment Lens for telephoto type (AL-UA4)

This lens is attached to the object lens of UA-200T or UA-200AT to broaden the angle of view.

UA-200TW measurement area: Telephoto lens+ Attachment lens, Focal length : f=14mm

Measurement distance (mm)	400	500	1,000	1,500	2,000	2,500
Display size (inch)	7.5	9.0	16.5	24.1	31.7	39.2
Horizontal (mm)	151.7	182.6	336.2	489.6	643.3	797.1
Vertical (mm)	113.8	136.9	252.1	367.2	482.5	597.8

UA-200ATW measurement area: Telephoto lens+ Attachment lens, Focal length : f=14mm

Measurement distance (mm)	400	500	1,000	1,500	2,000	2,500
Display size (inch)	8.0	9.6	17.7	25.8	33.9	42.1
Horizontal (mm)	163.1	196.3	361.4	526.3	691.5	856.9
Vertical (mm)	121.4	146.1	268.9	391.7	514.6	637.7

Dimension

UA-200S
UA-200AS

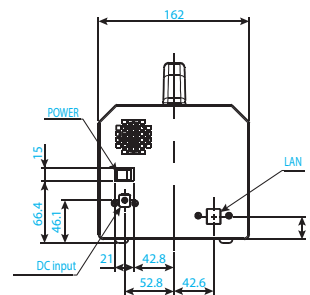
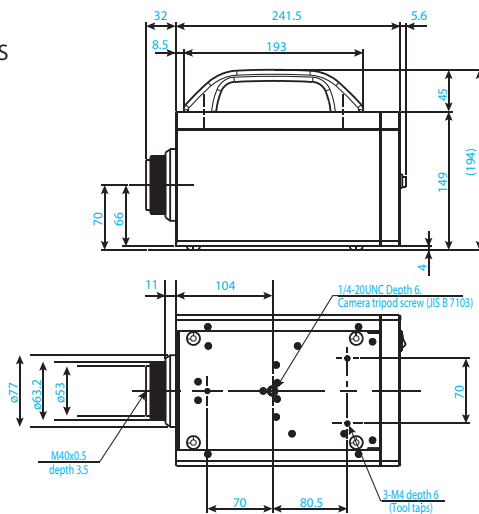

UA-200WS
UA-200AWS

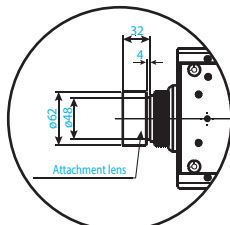
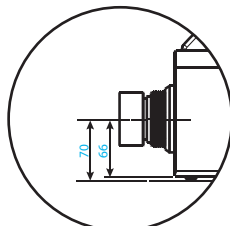

UA-200T
UA-200AT

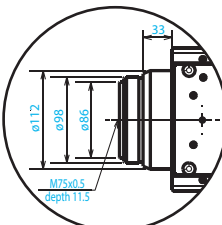
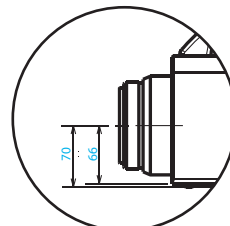

UA-200TW
UA-200ATW

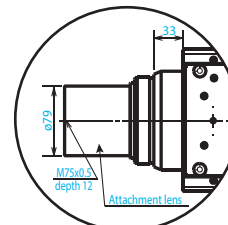
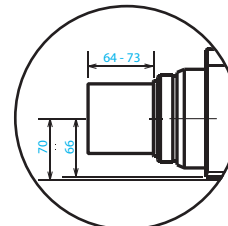

Unit: mm

Specification / Function

Model	UA-200S	UA-200WS	UA-200T	UA-200AS	UA-200AWS	UA-200AT
Objective lens	Standard type	Wide type *1	Telephoto type	Standard type	Wide type *1	Telephoto type
	Focal length : f=8mm	Focal length : f=5mm	Focal length : f=35mm	Focal length : f=8mm	Focal length : f=5mm	Focal length : f=35mm
Detector	1.3 mega pixel CCD image sensor			1.4 mega pixel CCD image sensor		
Effective pixel	1280×960			1376×1024		
Measurement range	0.05 to 1,000,000 cd/m ²			0.005 to 1,000,000cd/m ²		
Linearity in luminance	±2% (1 cd/m ² or more), ±3% (0.05 to 1 cd/m ²)			±2% (1 cd/m ² or more), ±3% (0.005 to 1cd/m ²) *2,*3		
Chromaticity accuracy	±0.003 (1cd/m ² or more), ±0.005 (0.05 to 1 cd/m ²)			±0.003 (1cd/m ² or more), ±0.005 (0.005 to 1cd/m ²) *2,*3		
	±0.008			±0.008 *3,*7		
				±0.005 *8		
In-plane uniformity	Luminance: ±2%			Luminance: ±2%		
	Chromaticity: ±0.003			Chromaticity: ±0.003 *2,*4		
Repeatability	Luminance: 0.3% (1cd/m ² or more), 0.5% (0.05 to 1 cd/m ²)			Luminance: 0.3% (1cd/m ² or more), 0.5% (0.005 to 1cd/m ²) *5		
	Chromaticity: 0.001 (1cd/m ² or more), 0.002 (0.05 to 1 cd/m ²)			Chromaticity: 0.001 (1cd/m ² or more), 0.002 (0.05 to 1cd/m ²), 0.0035 (0.005 to 0.05cd/m ²) *6		
Measurement time	About 1sec (Luminance), About 3 sec. (Color) (100 cd/m ² including data transfer time)			About 1.5sec (Luminance), About 3.5sec (Color) (100cd/m ² including data transfer time)		
Stability	Luminance: 1%			Luminance: 1%		
Reproducibility	Luminance: 2%			Luminance: 2%		
Temperature characteristic	Luminance: ±3% (0 – 40°C based on 25°C)			Luminance: ±3% (0 – 40°C based on 25°C)		
Humid characteristic	Luminance: ±3% (85%R.H. or below, No condensation)			Luminance: ±3% (85%R.H. or below, No condensation)		
Interface	LAN (Gigabit Ethernet)			LAN (Gigabit Ethernet)		
Power supply	AC 100 - 240V (50/60Hz) / Dedicated AC adapter (standard accessory)			AC 100 - 240V (50/60Hz) / Dedicated AC adapter (standard accessory)		
Power consumption	12V 24VA (excluding PC)			12V 24VA (excluding PC)		
Operation condition	Temp: 0 to 40°C, Humid: 85%R.H. or below (No condensation)			Temp: 0 to 40°C, Humid: 85%R.H. or below (No condensation)		
Storage condition	Temp: -5 to 50°C, Humid: 85%R.H. or below (No condensation)			Temp: -5 to 50°C, Humid: 85%R.H. or below (No condensation)		
Outer Dimension	279.1(L)×162(W)×194(H)mm	311.1(L)×162(W)×194(H)mm *1	307.1(L)×162(W)×194(H)mm	279.1(L)×162(W)×194(H)mm	311.1(L)×162(W)×194(H)mm *1	307.1(L)×162(W)×194(H)mm
Weight	About 3.9kg	About 4.12kg *1	About 4.45kg	About 3.9kg	About 4.12kg *1	About 4.45kg

*1: Standard lens+Attachment wide lens, *2: for standard illuminant A, *3: at the center of CCD, *4: at the center of CCD, *5: in 2σ, *6: Max value – Min value
*7: for reference luminance surface with Color glass (O-55,Y-48,A-73B,IRA-05,T-44,R-61,B-46,V-44,G-54) *8:Our specification LED panel of RGBW

UA-200S measurement area: Standard type

Measurement distance (mm)	300	400	500	1,000	1,500	2,000	2,500
Display size (inch)	8.9	11.6	14.2	27.6	40.9	54.1	67.5
Horizontal (mm)	181.5	235.3	289.4	561.0	830.8	1099.2	1371.4
Vertical (mm)	136.1	176.5	217.0	420.8	623.1	824.4	1028.6

UA-200WS measurement area: Wide type (Standard lens + Attachment wide lens)

Measurement distance (mm)	300	400	500	1,000	1,500	2,000	2,500
Display size (inch)	14.5	18.7	23.0	44.2	65.3	86.6	107.9
Horizontal (mm)	293.9	380.6	466.4	898.7	1326.8	1759.0	2192.9
Vertical (mm)	220.4	285.5	349.8	674.0	995.1	1319.2	1644.7

UA-200T measurement area: Telephoto type

Measurement distance (mm)	-	400	500	1,000	1,500	2,000	2,500
Display size (inch)	-	4.7	5.3	8.3	11.2	14.3	17.3
Horizontal (mm)	-	95.8	108.2	168.2	228.1	289.9	351.6
Vertical (mm)	-	71.9	81.1	126.2	171.1	217.4	263.7

UA-200AS measurement area: Standard type

Measurement distance (mm)	300	400	500	1,000	1,500	2,000	2,500
Display size (inch)	9.6	12.4	15.3	29.6	43.8	58.0	72.4
Horizontal (mm)	195.1	252.9	311.1	603.1	893.1	1181.7	1474.3
Vertical (mm)	145.2	188.2	231.5	448.8	664.6	879.4	1097.1

UA-200AWS measurement area: Wide type (Standard lens + Attachment wide lens)

Measurement distance (mm)	300	400	500	1,000	1,500	2,000	2,500
Display size (inch)	15.5	20.1	24.6	47.4	70.0	92.8	115.7
Horizontal (mm)	315.9	409.2	501.4	966.1	1426.3	1890.9	2357.4
Vertical (mm)	235.1	304.5	373.1	719.0	1061.4	1407.2	1754.3

UA-200AT measurement area: Telephoto type

Measurement distance (mm)	-	400	500	1,000	1,500	2,000	2,500
Display size (inch)	-	5.1	5.7	8.9	12.0	15.3	18.6
Horizontal (mm)	-	103.0	116.3	180.8	245.2	311.6	378.0
Vertical (mm)	-	76.6	86.6	134.6	182.5	231.9	281.3

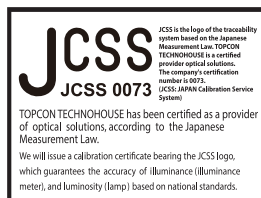

*Some screens are simulated.
*The specifications and external appearances of product in this catalogue may be changed without prior notice due to improvements.
*The catalogue includes products that are sold separately.
*The actual color of products may differ slightly from the catalogue due to lighting and printing conditions.

TOPCON TECHNOHOUSE CORPORATION

75-1 Hasunuma-cho, Itabashi-ku, Tokyo 174-8580 JAPAN
Phone: +81-3-3558-2666 Fax: +81-3-3558-4661
E-mail: techno-info@topcon.co.jp

SAFETY PRECAUTIONS



Make sure to carefully read the "Manual" to ensure that you use the product properly and safely.

•Always connect the instrument to the specified power supply voltage. Improper connection may cause a fire or electric shock.

For more information please visit our website.

<http://www.topcon-techno.co.jp/en/>

