



Add-on examples of Wireless data logger AirLogger™ application

All Rights Reserved - ADVANTEST CORPORATION

ADVANTEST®

Wireless data logger AirLogger™ series



WM2000TA/TB
(Temperature · Voltage 2/7ch)



Thermocouple



Humidity sensor



Anemometer sensor



Illuminance sensor



WM2000SA/Full Bridge
(static strain measurement)



Strain gauge
(static strain, dynamic strain)
(Axial tension, Axial torque)



Load cell



Pressure transducer
(hydraulic, water pressure, gas pressure)



Speed converter
(Accelerometer, vibration)

*** Sampling should be slower than 100msec**

Application example No.1

Deal with monitor of the insertion distance during pile driving work on the bedrock.

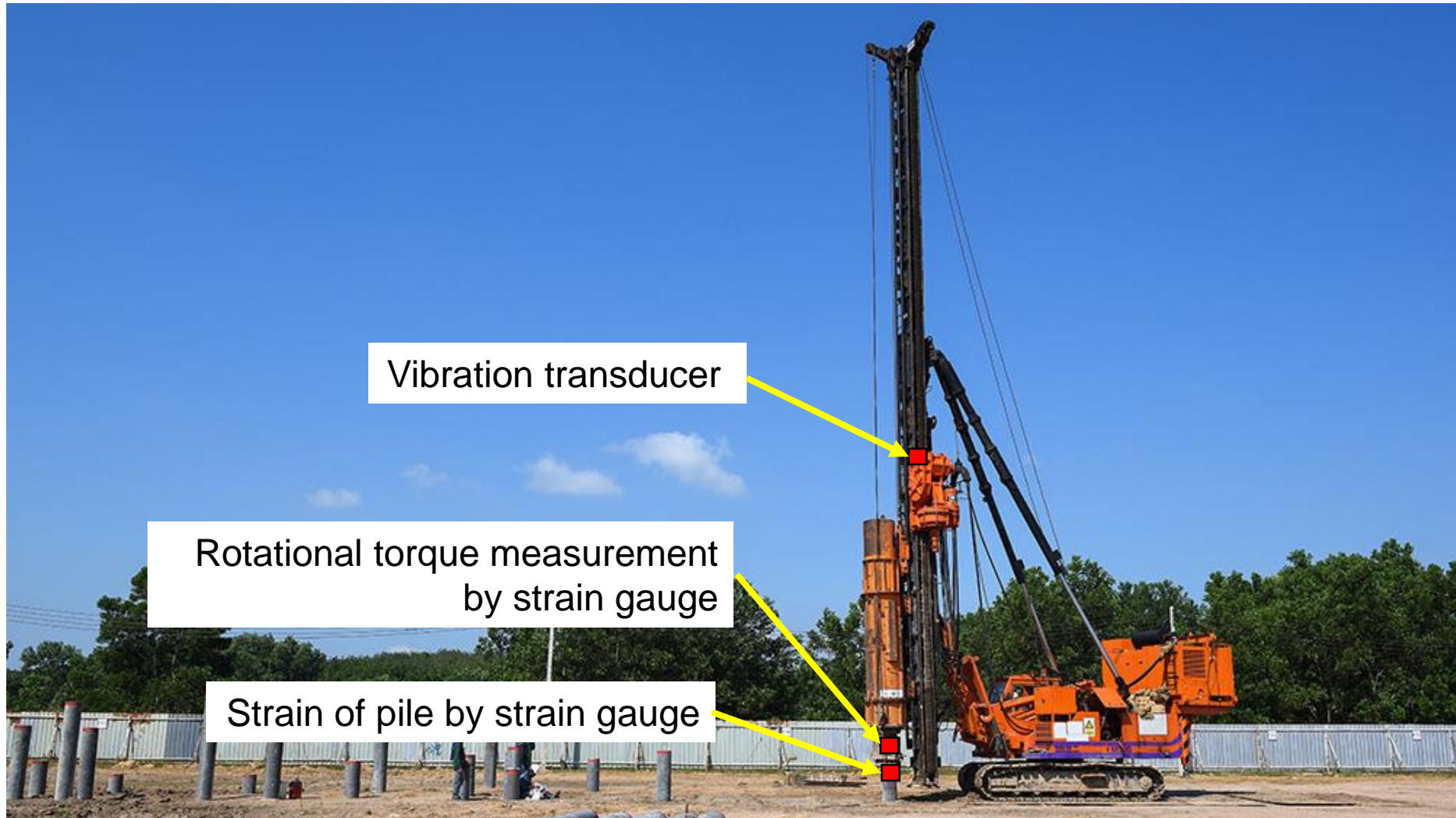

Application example No.2

operation verification of KAZ-740P in coarse mode

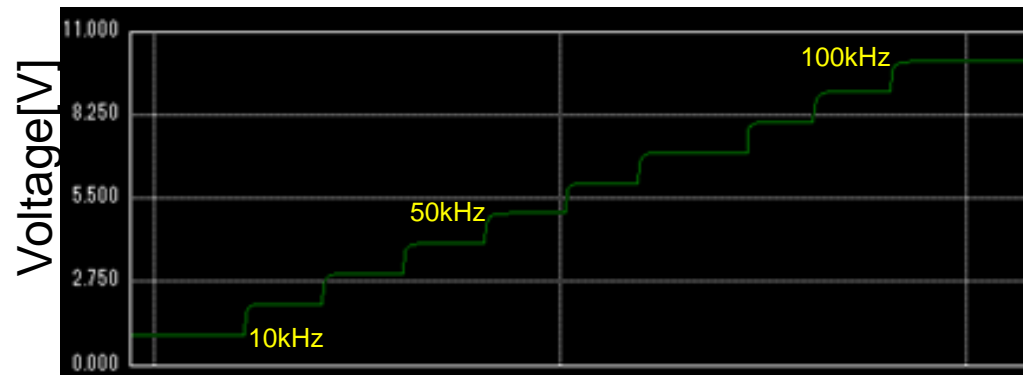
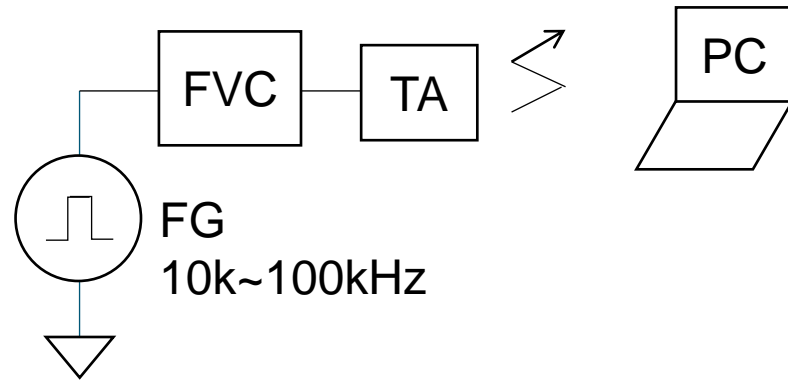
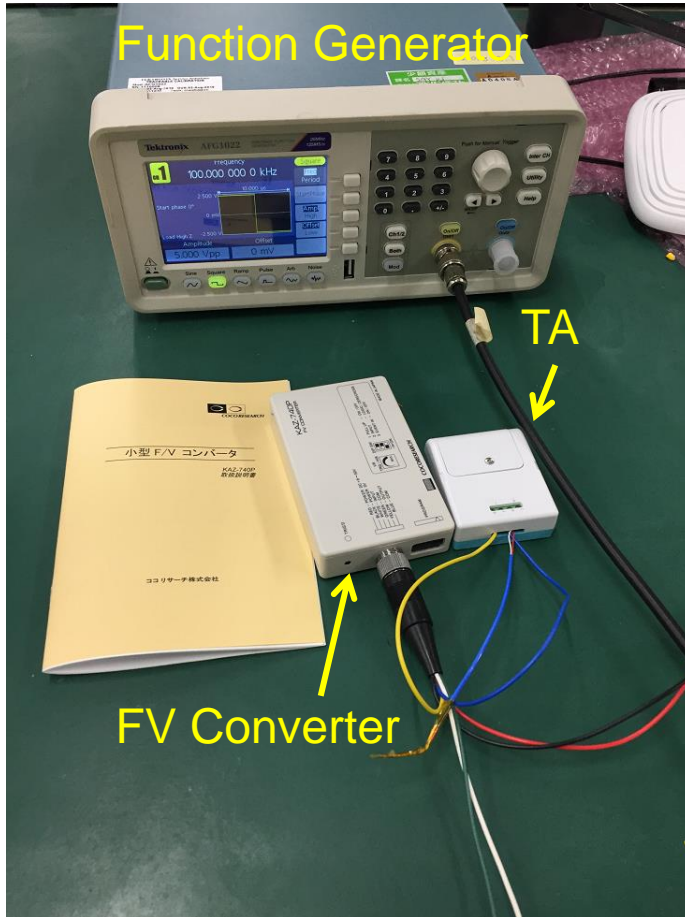

The situation of sudden stop or speed-change

Application example No.3

The monitoring fatigue status of Industrial robot

Copyright 2018 ADVANTEST CORPORATION

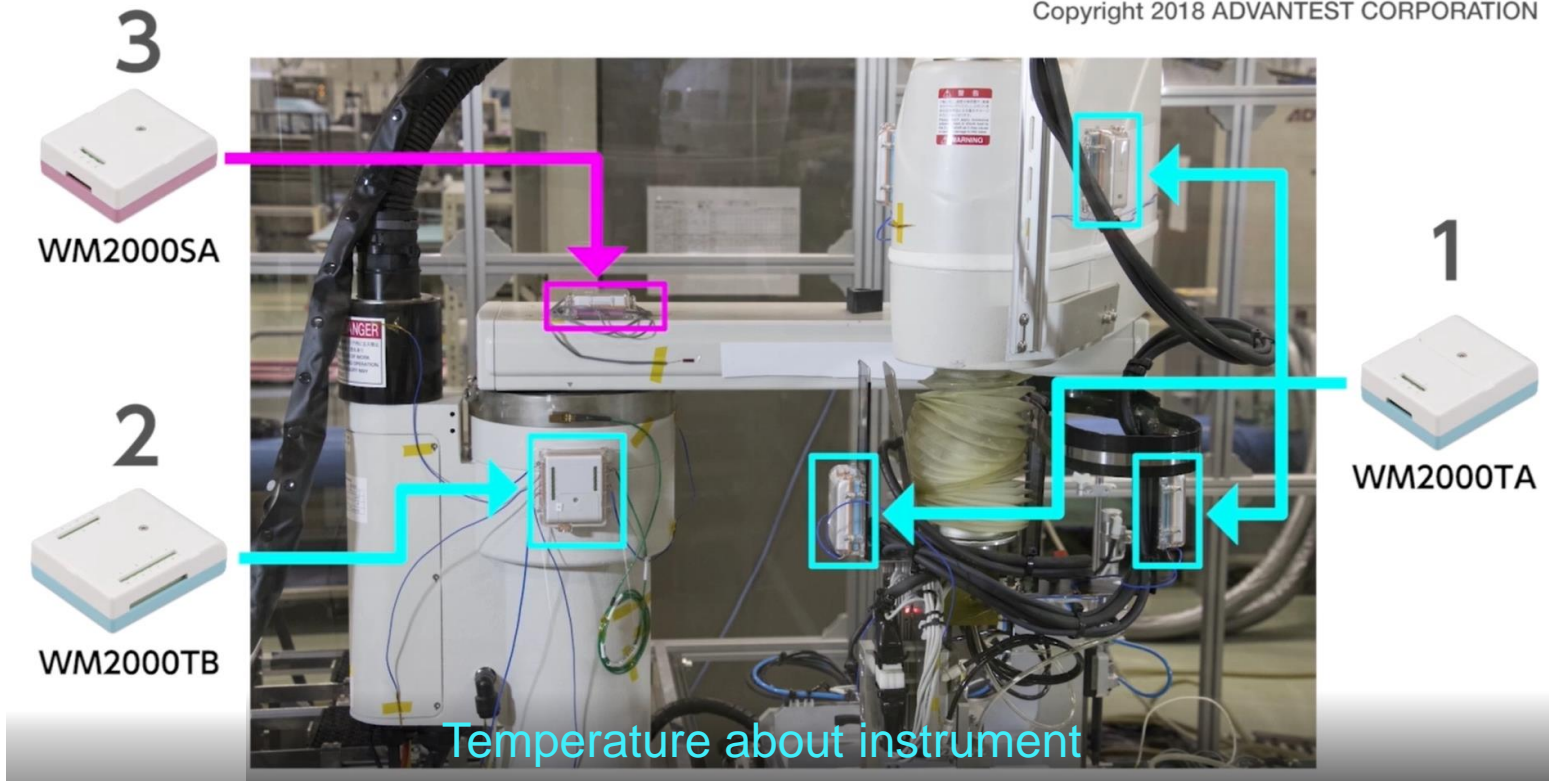

Application example No.4

WM2000 series could be connected with transducer.

Transducer example:

[Search for pressure transducers | KYOWA \(kyowa-ei.com\)](#)

[Transducers | Tokyo Measuring Instruments Laboratory Co., Ltd. \(tml.jp\)](#)

We recommend consulting with us beforehand.